

**Ritzwell**  
EXPERIENCE JAPAN

THE COLLECTION | NEWS 2018

## RITZWELL IS COMFORTABLE DESIGN FOR HUMAN LIVING

Since our establishment in 1992 Ritzwell has steadfastly continued to make furniture to Japanese sensitivity. The deep feelings of both designers and users for our furniture grow over time, making each piece a beloved friend... and that recognition drives us to pour our hearts into new masterpieces. Each Ritzwell design is born of the gentle flow of time in our daily lives. Ritzwell breathes the essence of warmth into our furniture by combining quality materials with delicate craftsmanship. This isn't mass production: this is the creation of art to blend into your daily lives. Beautiful furniture: quiet, subtle, but undeniably an expressive presence in your room. Like music or art, our goal is to make furniture that becomes a part of your daily life, surpassing artificial boundaries of culture and custom to bring peace and tranquility to people everywhere.

### CHAIRS AND STOOLS

05 | BEATRIX 13 | CLAUDE 15 | MARCEL 17 | RIVAGE 21 | IBIZA FORTE  
23 | BLAVA 25 | LUPIN 27 | VINCENT

### SIDEBORD

09 | JABARA

### TABLES

29 | IBIZA FORTE 33 | MO TABLE 37 | OS TABLE 39 | MCM TABLE

### SOFAS

43 | LIGHT FIELD 47 | LIGHT FIELD CHAISE LONGUE 49 | DIANA





**BEATRIX** | DESIGN SHINSAKU MIYAMOTO  
HIGH BACK EASY CHAIR 2017 AND OTTOMAN 2018

FRAME: WALNUT OIL FINISH | SEAT AND BACK: LEATHER | SHELL: THICK LEATHER (VINTAGE BROWN)

| NEW |



CONSISTING OF A VARIETY OF ELEMENTS, THE BEATRIX HIGH-BACK EASY CHAIR WAS DEVELOPED OVER MANY YEARS OF EXPERIMENTATION, ON THE BASIS OF THE AESTHETIC SENSIBILITIES AND SUPERIOR TECHNOLOGICAL PROWESS OF JAPAN. THE EXCEPTIONAL CONSCIENTIOUSNESS AND ATTENTION TO DETAIL OF JAPANESE CRAFTSPEOPLE ARE NECESSARY FOR THE CHAIR'S PRODUCTION. ALTHOUGH THIS CHAIR IS NOT SUITED TO MASS PRODUCTION, IN ORDER TO MAKE SOMETHING THAT RESONATES WITHIN THE HEART OF THE USER, WE BELIEVE IT IS ESSENTIAL TO MAKE THAT ITEM BY HAND, ONE BY ONE, WITH LOVING CARE.



HIGH BACK EASY CHAIR | 2017  
FRAME: WALNUT OIL FINISH  
SEAT AND BACK: LEATHER  
SHELL: THICK LEATHER (BLACK)



HIGH BACK EASY CHAIR | 2017  
FRAME: OAK OIL FINISH (WHITE)  
SEAT AND BACK: FABRIC  
SHELL: THICK LEATHER (BLACK)



HIGH BACK EASY CHAIR | 2017 AND OTTOMAN | 2018  
FRAME: WALNUT OIL FINISH  
SEAT AND BACK: LEATHER  
SHELL: THICK LEATHER (BLACK)







**JABARA** | DESIGN SHINSAKU MIYAMOTO

SIDEBOARD 2018

BODY: WALNUT POLYURETHANE FINISH | BASE: STEEL IN BLACK  
FRONT DRAWER: THICK LEATHER | DOOR: SLIDING TAMBOUR DOOR

| NEW |



reddot design award  
winner 2018



SIDEBOARD | 2018

BODY: OAK POLYURETHANE FINISH (WHITE)  
BASE: STEEL IN BLACK



SIDEBOARD | 2018

BODY: WALNUT POLYURETHANE FINISH  
BASE: STEEL IN BLACK



SIDEBOARD | 2018

BODY: WALNUT POLYURETHANE FINISH  
BASE: STEEL IN BLACK

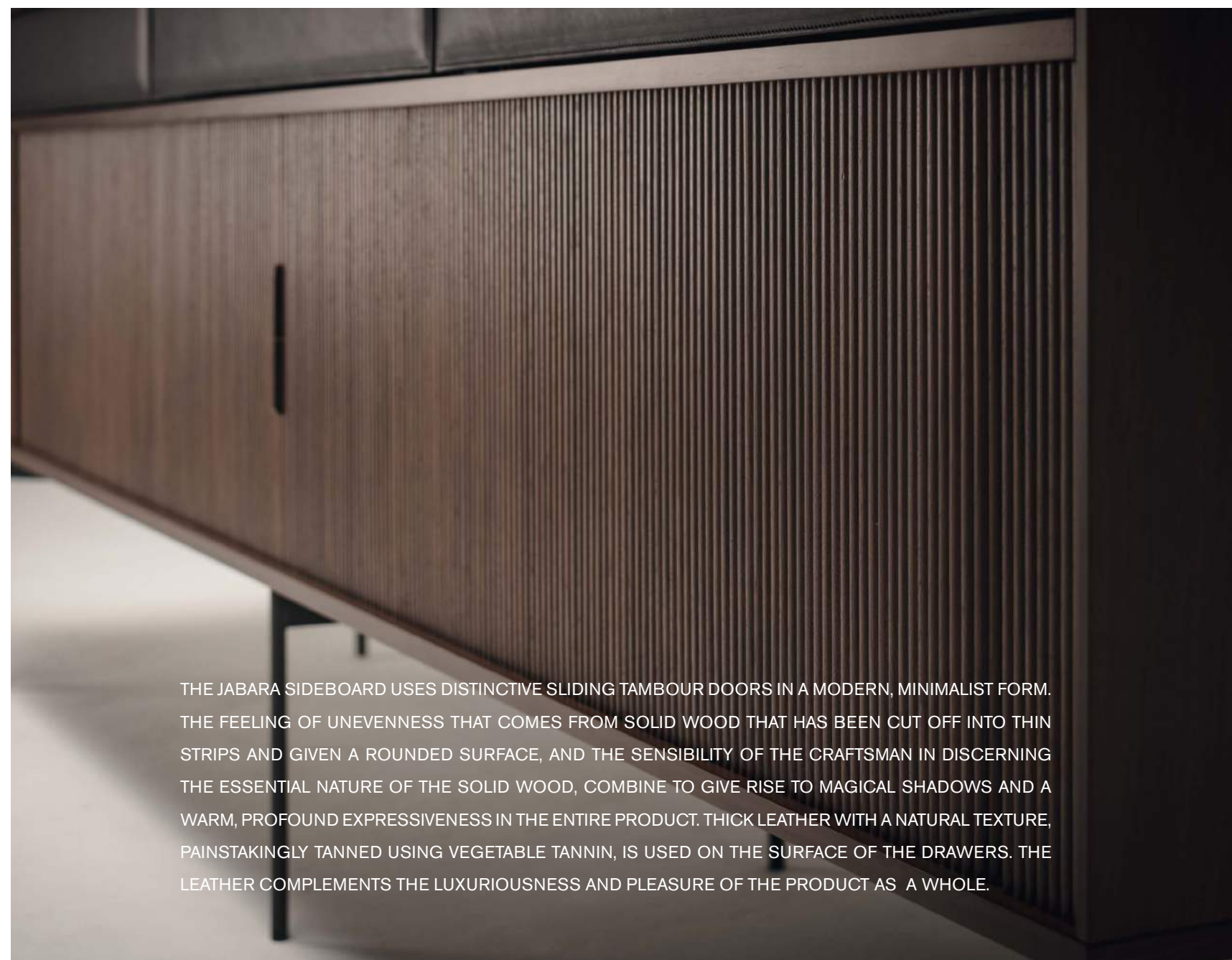

THE JABARA SIDEBOARD USES DISTINCTIVE SLIDING TAMBOUR DOORS IN A MODERN, MINIMALIST FORM. THE FEELING OF UNEVENNESS THAT COMES FROM SOLID WOOD THAT HAS BEEN CUT OFF INTO THIN STRIPS AND GIVEN A ROUNDED SURFACE, AND THE SENSIBILITY OF THE CRAFTSMAN IN DISCERNING THE ESSENTIAL NATURE OF THE SOLID WOOD, COMBINE TO GIVE RISE TO MAGICAL SHADOWS AND A WARM, PROFOUND EXPRESSIVENESS IN THE ENTIRE PRODUCT. THICK LEATHER WITH A NATURAL TEXTURE, PAINSTAKINGLY TANNED USING VEGETABLE TANNIN, IS USED ON THE SURFACE OF THE DRAWERS. THE LEATHER COMPLEMENTS THE LUXURIOUSNESS AND PLEASURE OF THE PRODUCT AS A WHOLE.







**CLAUDE** | DESIGN SHINSAKU MIYAMOTO

EASY CHAIR 2013

FRAME: WALNUT OIL FINISH | SEAT AND BACK: LEATHER



THE DETAILING ON THE SCULPTURED ARMRESTS AND THE LINES OF THE LEGS ARE UNIQUE, AND ESPECIALLY THE FLAWLESS CARVING OF THE ARMRESTS SUGGESTS THE ANCIENT STATUES OF BUDDHA, CREATING A TOOLED YET EVEN FINISH. THE POWERFUL DESIGN ENCOMPASSES TRANQUILITY AND QUIETUDE... A DESIGN THAT COMBINES OLD ELEMENTS INTO SOMETHING STUNNINGLY NEW.



**CHAIR | 2016**  
FRAME: OAK OIL FINISH (WHITE)  
SEAT AND BACK: LEATHER



**ARMCHAIR | 2013**  
FRAME: WALNUT OIL FINISH  
SEAT AND BACK: FABRIC



**EASY CHAIR | 2016**  
FRAME: OAK OIL FINISH (WHITE)  
SEAT AND BACK: LEATHER





**CHAIR | 2016**  
FRAME: OAK OIL FINISH (WHITE)  
BACK PANEL: OAK POLYURETHANE FINISH (BLACK)  
SEAT AND BACK: LEATHER



**CHAIR | 2013**  
FRAME: WALNUT OIL FINISH  
BACK PANEL: WALNUT POLYURETHANE FINISH  
SEAT AND BACK: LEATHER



**CHAIR | 2016**  
FRAME: OAK POLYURETHANE FINISH (BLACK)  
BACK PANEL: OAK POLYURETHANE FINISH (BLACK)  
SEAT AND BACK: LEATHER



THE FORM FULLY UTILIZES MODERN WOODWORKING TECHNOLOGY, COMBINED WITH THE EXPERTISE AND EXPERIENCE OF DESIGNERS WHO TRULY UNDERSTAND WOOD AND ITS CHARACTERISTICS. THE NATURAL FEEL OF THE BASIC WALNUT IS PRESERVED, BRINGING OUT THE WARMTH OF THE WOOD, AND THE BEAUTIFUL LINE FROM THE REAR LEGS UP THROUGH THE BACK ENFOLDS YOU IN GENTLE ELEGANCE.



**RIVAGE** | DESIGN ATELIER D.O.  
EASY CHAIR 2011  
FRAME: WALNUT OIL FINISH | SEAT AND BACK: LEATHER



**ARMCHAIR | 2011**  
FRAME: WALNUT OIL FINISH  
SEAT AND BACK: LEATHER



**EASY CHAIR | 2016**  
FRAME: WALNUT OIL FINISH  
SEAT AND BACK: LEATHER



**STOOL | 2016**  
FRAME: OAK POLYURETHANE FINISH (BLACK)  
SEAT: LEATHER







**IBIZA FORTE** | DESIGN JUN KAMAHARA

ARMCHAIR 2004

FRAME: WALNUT OIL FINISH | SEAT: LEATHER | BACK: THICK LEATHER (BLACK)



**DETAIL | ARMCHAIR | 2016**  
FRAME: OAK OIL FINISH (WHITE)  
SEAT: LEATHER  
BACK: THICK LEATHER (BLACK)





**BLAVA** | DESIGN ATELIER D.O.

EASY CHAIR 2007

FRAME: WALNUT OIL FINISH | CUSHION: LEATHER | BELT: THICK LEATHER (BLACK)



**HIGH BACK EASY CHAIR | 2016**  
FRAME: OAK POLYURETHANE FINISH (BLACK)  
CUSHION: FABRIC  
BELT: THICK LEATHER (BLACK)



**EASY CHAIR | 2016**  
FRAME: OAK OIL FINISH (WHITE)  
CUSHION: LEATHER  
BELT: THICK LEATHER (BLACK)



**HIGH BACK EASY CHAIR AND OTTOMAN | 2011**  
FRAME: WALNUT OIL FINISH  
CUSHION: FABRIC  
BELT: THICK LEATHER (VINTAGE BROWN)



**LUPIN** | DESIGN ATELIER D.O.

LOUNGE CHAIR 2014

FRAME: WALNUT OIL FINISH AND THICK LEATHER (BLACK) | PADDING AND CUSHION: FABRIC



THE SQUARE FORM OF THE SOFA IMPARTS A FEELING OF RELAXATION AND COMFORT. WHILE COMPOSED OF FLAT SURFACES ON THREE SIDES IT EVOLVES INTO A THREE-DIMENSIONAL FORM RICH IN ORGANIC BEAUTY. THE LUXURIOUS BASE OF THICK LEATHER IS ACCENTUATED WITH A BELT DESIGN BRINGING OUT THE FULL BEAUTY OF THE MATERIALS. THE INTERPLAY OF LIGHT AND SHADOW ON THE DELICATE TEXTURE REVEALS ITS QUIET, REFINED FEEL. ALVAR AALTO ONCE SAID, "THE FURNITURE, THE FABRICS, THE COLOR SCHEMES AND THE STRUCTURES CAN BE EARNESTLY AND HAPPILY MADE SO THAT THEY PRODUCE NO CONTRAST TO THE TRAGEDY AND COMEDY OF HUMAN LIFE". AND IN KEEPING WITH HIS PHILOSOPHY OUR SOFA INCORPORATES SOFTNESS INTO ITS VERY DESIGN FOR SATISFYINGLY DEEP COMFORT AND RELAXATION.



STOOL 2016

FRAME: OAK POLYURETHANE FINISH (BLACK) | BELT: THICK LEATHER (BLACK)



STOOL | 2011

FRAME: WALNUT OIL FINISH  
BELT: THICK LEATHER (VINTAGE BROWN)



STOOL | 2016

FRAME: OAK POLYURETHANE FINISH (BLACK)  
BELT: THICK LEATHER (BLACK)



STOOL | 2016

FRAME: OAK OIL FINISH (WHITE)  
BELT: THICK LEATHER (BLACK)





**IBIZA FORTE** | DESIGN JUN KAMAHARA  
COFFEE TABLE 2004  
TABLE TOP: WALNUT OIL FINISH | LEG: STEEL IN BLACK



COFFEE TABLES | 2004  
TABLE TOP: WALNUT OIL FINISH  
LEG: STEEL IN BLACK







**MO TABLE** | DESIGN SHINSAKU MIYAMOTO  
COFFEE TABLE 2016  
TABLE TOP AND LEG: OAK OIL FINISH (WHITE)



**DINING TABLE | 2016**  
TABLE TOP AND LEG: OAK POLYURETHANE FINISH (BLACK)



**SIDE TABLE | 2016**  
TABLE TOP AND LEG: OAK OIL FINISH (WHITE)



**COFFEE TABLE | 2016**  
TABLE TOP AND LEG: OAK POLYURETHANE FINISH (BLACK)

THESE ROUND TABLES BRING A WARM, GENTLE FEELING TO EVERY SCENE. WITH A ROUNDED TABLE TOP EDGE AND DELIGHTFUL LEG LINES, THE STRENGTH OF SOLID WOOD SHINES THROUGH IN THIS MODERN DESIGN. THE QUALITY LOOK AND FEEL OF NATURAL WOOD BRING TRANQUILITY. COMBINE A NUMBER OF DINING, COFFEE OR SIDE TABLES FREELY TO CREATE AN INFINITE ARRAY OF NOOKS AND GATHERINGS.







**OS TABLE** | DESIGN RITZWELL  
SIDE TABLE 2014  
TABLE TOP: WALNUT OIL FINISH | LEG: STEEL IN BLACK



**SIDE TABLE | 2016**  
TABLE TOP: OAK POLYURETHANE FINISH (BLACK)  
LEG: STEEL IN BLACK



**SIDE TABLE | 2016**  
TABLE TOP: OAK OIL FINISH (WHITE)  
LEG: STEEL IN BLACK



**MCM TABLE** | DESIGN SHINSAKU MIYAMOTO

DINING TABLE 2015

TABLE TOP AND LEG: WALNUT OIL FINISH | FRAME: STEEL IN BLACK



ONLY SUPPORTED BY FOUR LEGS, ITS SIMPLE DESIGN HIGHLIGHTS THE THINNESS OF THE TABLE TOP. THIS SUPERB, MODERN LOOKING LONG SIZE TABLE COMBINES STRENGTH AND DESIGNABILITY. ITS DETAILED DESIGN, WHICH ADDS TO THE WONDERFUL APPEARANCE AND ROUNDNESS OF A WOOD GRAIN TABLE TOP THAT CAN ONLY BE CREATED WITH NATURAL WOOD, ALSO ALLOWS ONE TO FEEL THE STRONG PRESENCE AND GENTLENESS THAT WOOD POSSESSES, AS WELL AS BRINGING A BEAUTIFUL BALANCE TO COMFORTABLE, RELAXING SPACES.









## LIGHT FIELD | DESIGN SHINSAKU MIYAMOTO

MODULAR SOFA 2014

FRAME: FABRIC, LEATHER AND THICK LEATHER COVERED PANELS

PADDING AND CUSHION: FABRIC AND LEATHER | LEG: STEEL IN BLACK AND STAINLESS STEEL



THE LUXURIOUS CUSHION ENSURES RELAXATION, WHILE THE STRIKING LEATHER FORM IS LIGHT, AIRY. THIS EXQUISITE PIECE OFFERS A DELICATE BALANCE OF QUIETUDE AND TENSION. THE THICK LEATHER IS PREPARED WITH TANNIN TO BRING OUT ITS FULL BEAUTY, AND STITCHED WITH CARE TO LEVERAGE THE QUALITY OF THE HIGH-GRADE MATERIALS INTO A MASTERPIECE OF UNDERSTATEMENT. FABRIC CUSHIONS ENFOLD YOU IN COMFORT, ADDING SOFTNESS TO THE WHOLE AND REALIZING A BOLD AND ELEGANT ADDITION TO YOUR ROOM.



1 SEATER SOFA | 2014

FRAME: THICK LEATHER COVERED PANELS (BLACK)

PADDING AND CUSHION: FABRIC AND LEATHER

LEG: STEEL IN BLACK



3 SEATER SOFA | 2014

FRAME: FABRIC COVERED PANELS

PADDING AND CUSHION: FABRIC AND LEATHER

LEG: STEEL IN BLACK

DETAIL | 1 SEATER SOFA | 2014  
FRAME: THICK LEATHER COVERED PANELS (BLACK)  
PADDING AND CUSHION: FABRIC



ANGULAR SOFA | 2014  
FRAME: THICK LEATHER COVERED PANELS (BLACK)  
PADDING AND CUSHION: FABRIC AND LEATHER  
LEG: STAINLESS STEEL



ANGULAR SOFA | 2014  
FRAME: LEATHER COVERED PANELS  
PADDING AND CUSHION: FABRIC AND LEATHER  
LEG: STEEL IN BLACK





**LIGHT FIELD** | DESIGN SHINSAKU MIYAMOTO

CHAISE LONGUE 2017

FRAME: FABRIC, LEATHER AND THICK LEATHER COVERED PANELS | PADDING AND CUSHION: FABRIC AND LEATHER

LEG: STEEL IN BLACK AND STAINLESS STEEL



CHAISE LONGUE | 2017

FRAME: THICK LEATHER COVERED PANELS (BLACK)

PADDING AND CUSHION: FABRIC

LEG: STEEL IN BLACK



**DIANA** | DESIGN SHINSAKU MIYAMOTO

1 SEATER SOFA 2015

FRAME: WALNUT OIL FINISH | FRAME COVER: LEATHER | CUSHION: LEATHER



1 SEATER SOFA | 2015  
FRAME: WALNUT OIL FINISH  
FRAME COVER AND CUSHION: LEATHER



THE CHARACTERISTIC LINE OF THE BACK AND ARM FRAME, CURVING TO ENCOMPASS YOUR BODY, GIVES THE DESIGN A POWERFUL VISUAL IMPACT COMBINED WITH THE UNIQUE TRANQUILITY OF JAPAN. THE LEATHER WRAPPINGS ON THE FRAME ADJUST THE FEEL OF THE WOOD, BRINGING ITS WILD NATURE UNDER CONTROL AND CAMOUFLAGING ITS FORM TO MAKE THE WALNUT STAND OUT EVEN MORE. THE HUES OF THE LEATHER ARE AS CLOSE TO NATURAL AS POSSIBLE, BALANCING WELL WITH THE WALNUT AS NO INORGANIC, UNIFORM COLOR COULD. THE FUSION OF WALNUT AND LEATHER CREATES A HIGH-GRADE FEEL, AND EXPRESSES THE AMBIANCE OF JAPAN THROUGH WOOD, LEATHER AND CLOTH.





3 SEATER SOFA | 2013  
FRAME: WALNUT OIL FINISH  
FRAME COVER: LEATHER  
CUSHION: FABRIC



3 SEATER SOFA | 2016  
FRAME: OAK OIL FINISH (WHITE)  
FRAME COVER AND CUSHION: LEATHER



OTTOMAN | 2016  
FRAME: OAK OIL FINISH (WHITE)  
FRAME COVER AND CUSHION: LEATHER



3 SEATER SOFA | 2013  
FRAME: WALNUT OIL FINISH  
FRAME COVER: LEATHER  
CUSHION: FABRIC



05 |  
**BEATRIX**  
 Design: SHINSAKU MIYAMOTO  
 Seat and back in fabric and leather  
 Frame in walnut, oak  
 Shell in thick leather  
 Black, burgundy and vintage brown thick leather

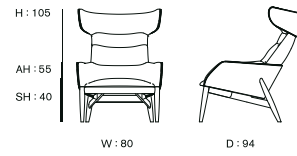

HIGH BACK EASY CHAIR



OTTOMAN

23 |  
**BLAVA**  
 Design: ATELIER D.Q.  
 Seat and back in removable fabric and leather  
 Belt in thick leather  
 Natural, black, burgundy and vintage brown thick leather  
 Frame in walnut, oak

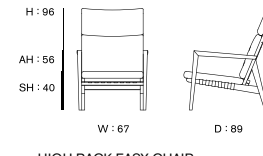

HIGH BACK EASY CHAIR

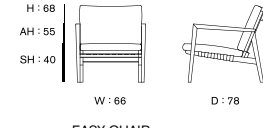

EASY CHAIR



OTTOMAN

13 |  
**CLAUDE**  
 Design: SHINSAKU MIYAMOTO  
 Seat and back in fabric and leather  
 Frame in walnut, oak

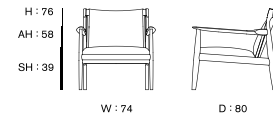

EASY CHAIR

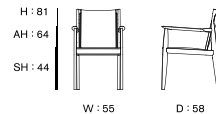

ARMCHAIR

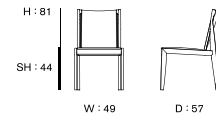

CHAIR

25 |  
**LUPIN**  
 Design: ATELIER D.Q.  
 Seat and back in fabric and leather  
 Frame in walnut, oak  
 Outside of seat and back in thick leather  
 Natural, black, burgundy and vintage brown thick leather

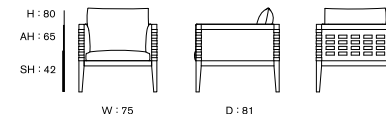

LOUNGE CHAIR

15 |  
**MARCEL**  
 Design: SHINSAKU MIYAMOTO  
 Seat and back in fabric and leather  
 Frame in walnut, oak

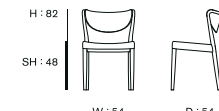

CHAIR

27 |  
**VINCENT**  
 Design: RITZWELL  
 Seat with thick leather webbing  
 Natural, Black, Burgundy and Vintage brown thick leather  
 Frame in walnut, oak

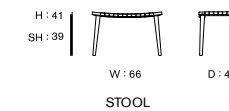

STOOL

17 |  
**RIVAGE**  
 Design: ATELIER D.Q.  
 Seat and back in fabric and leather  
 Frame in walnut, oak

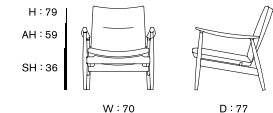

EASY CHAIR

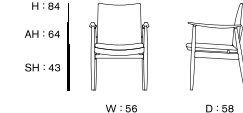

ARMCHAIR



STOOL

09 |  
**JABARA**  
 Design: SHINSAKU MIYAMOTO  
 Body in walnut, oak  
 Base in powder coated steel in black  
 Front drawer in black thick leather

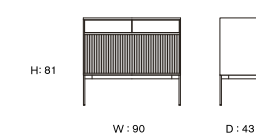

W: 90 D: 43

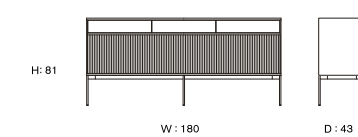

W: 180 D: 43

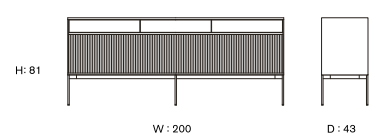

W: 200 D: 43

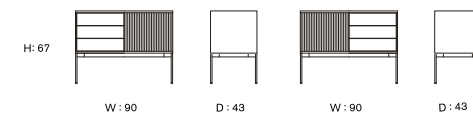

W: 90 D: 43

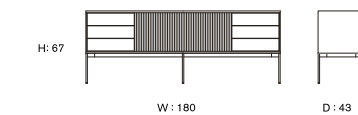

W: 180 D: 43

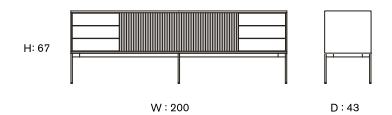

W: 200 D: 43

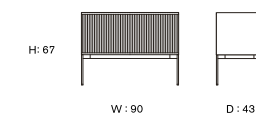

W: 90 D: 43

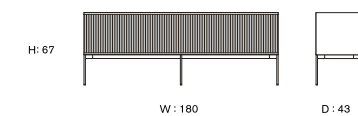

W: 180 D: 43

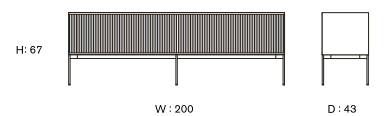

W: 200 D: 43

SIDEBOARD

21 |  
**IBIZA FORTE**  
 Design: JUN KAMAHARA  
 Seat in fabric and leather  
 Back in thick leather  
 Natural, black, burgundy and vintage brown thick leather  
 Frame in walnut, oak

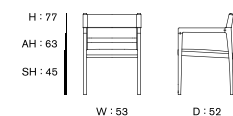

ARMCHAIR



29 |  
**IBIZA FORTE**  
 Design: JUN KAMAHARA  
 Top in solid walnut  
 Leg in powder coated steel in black

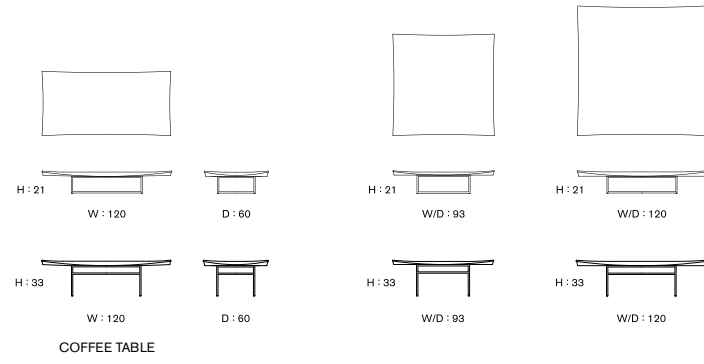

33 |  
**MO TABLE**  
 Design: SHINSAKU MIYAMOTO  
 Top in solid oak, walnut  
 Leg in solid oak

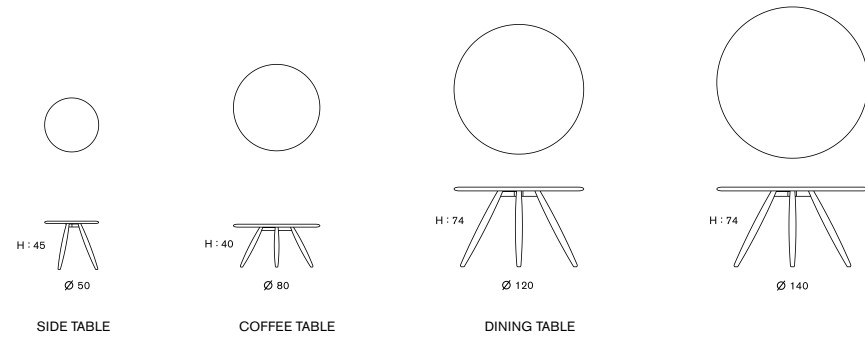

37 |  
**OS TABLE**  
 Design: RITZWELL  
 Top in solid walnut, oak  
 Leg in powder coated steel in black

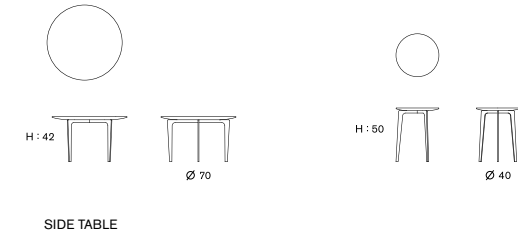

39 |  
**MCM TABLE**  
 Design: SHINSAKU MIYAMOTO  
 Top and leg in solid walnut  
 Frame in powder coated steel in black

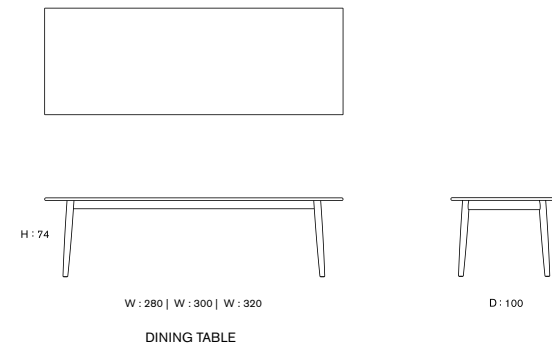

43 |  
**LIGHT FIELD**  
 Design: SHINSAKU MIYAMOTO  
 Seat and back cushion in removable fabric and leather  
 Outer panel in removable fabric, leather and thick leather  
 Leg in powder coated steel in black and stainless steel  
 Thick leather available in black, burgundy and vintage brown  
 - - - - Sewing scheme in leather

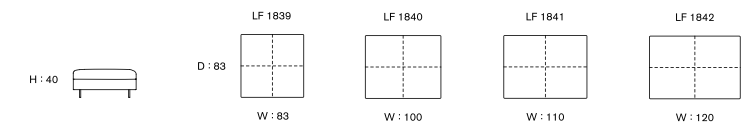
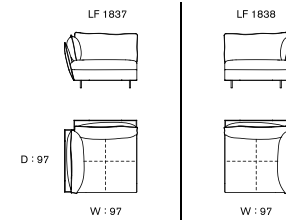
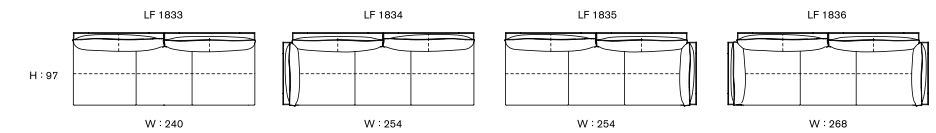
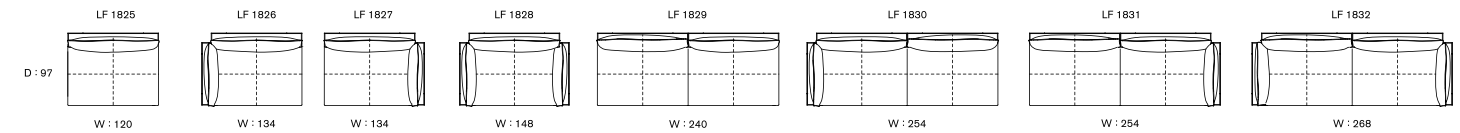
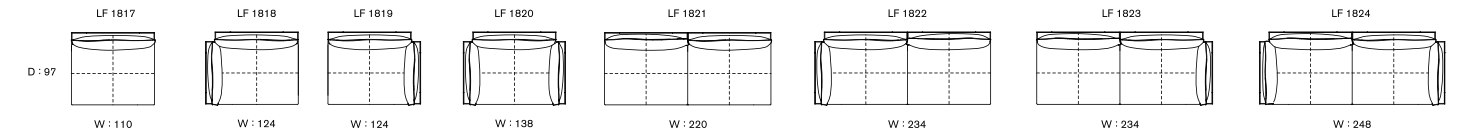
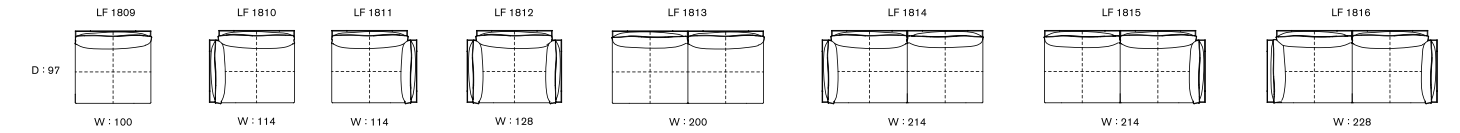
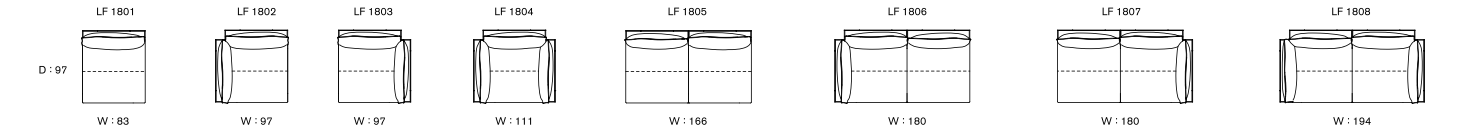



47 |

**LIGHT FIELD**

Design: SHINSAKU MIYAMOTO

Seat and back cushion in removable fabric and leather

Outer panel in removable fabric, leather and thick leather

Leg in powder coated steel in black and stainless steel

Thick leather available in black, burgundy and vintage brown

----- Sewing scheme in leather

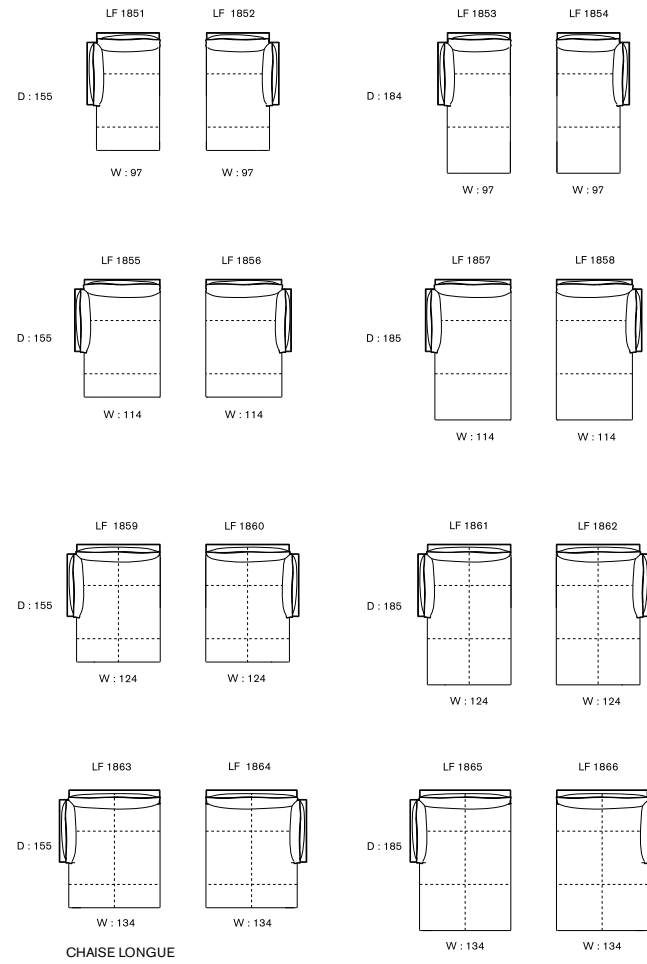

CHAISE LONGUE

49 |

**DIANA**

Design: SHINSAKU MIYAMOTO

Seat and back in removable fabric and leather

Frame cover in removable fabric and leather

Frame in walnut, oak

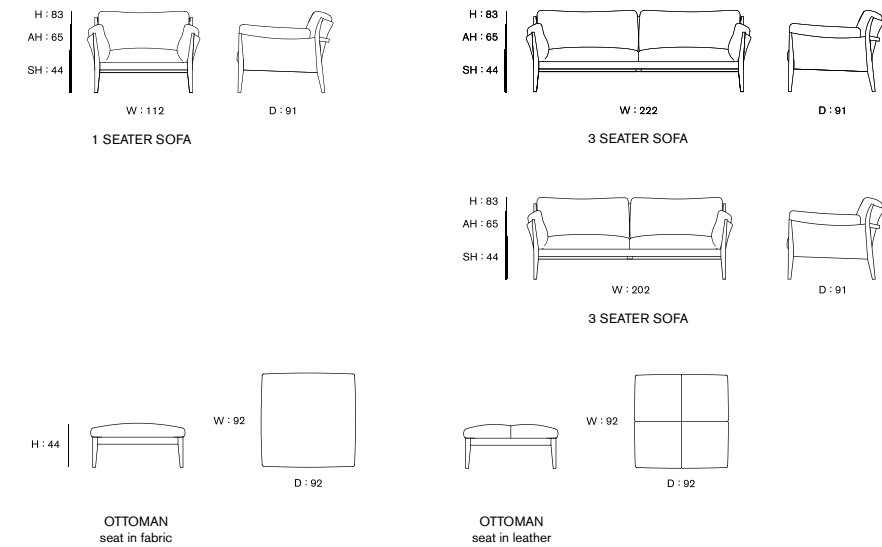

| TECHNICAL DATA



AS AWARDED BY THE DESIGN ZENTRUM NORDRHEIN WESTFALEN E.V.



AS AWARDED BY IF INTERNATIONAL FORUM DESIGN GMBH



AS AWARDED BY THE CHICAGO ATHENAEUM: MUSEUM OF ARCHITECTURE AND DESIGN



GRAPHIC DESIGN  
UNTITLED-AGENCY Milano

PRINTED IN ITALY  
ROTOLITO S.p.A.

**Ritzwell**

RITZWELL & CO. | TOKYO | OSAKA | FUKUOKA  
RITZWELL ITALIA S.R.L. | MILANO  
info@ritzwell.com | www.ritzwell.com



