

EXPERIENCE
JAPAN
THE COLLECTION
NEWS 2025

Ritzwell

DEAR CONNOISSEUR OF FINE LIVING, YOU ARE HOLDING IN YOUR HANDS THE COLLECTION OF OUR LATEST ADVANCEMENTS IN SENSORY, AESTHETIC AND METAPHYSICAL HARMONY. EACH FURNITURE PIECE IS DESIGNED WITH PURPOSE TO EMBRACE YOUR LIGHT AND ILLUMINATE YOUR DAYS AHEAD. NOW, LET THE DISCOVERY BEGIN. TURN THE PAGE AND STEP INTO THE MEDITATIVE WORLD OF RITZWELL.



CHAIRS, STOOLS AND DESK

08 | VESPER
10, 13 | CONSTANTINO
20 | MERCURY
26 | VERSE
30, 31, 32, 33 | MO BRIDGE
34 | MT BENCH
36, 39, 40, 43 | RIVAGE
46, 47, 53 | JK
48 | CLAUDE
50 | MARCEL
52 | LUPIN
54 | BLAVA
56 | VINCENT
82 | BEATRIX

STORAGES

58, 62 | JABARA

TABLES

16 | MT COFFEE TABLE
24 | GQ TABLE
44 | MTM TABLE
66 | OS TABLE
68, 71 | JK TABLE
72, 74 | MO TABLE
76 | MCM TABLE
78 | MT TABLE

SOFAS

04 | VELAR
80 | LEWISE EXCLUSIVE
86 | LIGHT FIELD
92 | DIANA

VELAR | DESIGN SHINSAKU MIYAMOTO

MODULAR SOFA 2025

FRAME AND CUSHION: FABRIC

PIPING: ARTIFICIAL SUEDE LEATHER

LEG: STEEL (BLACK)

| NEW |

BORN FROM THE LATIN "TO WRAP," VELAR IS A WORD OF ENCHANTMENT. IT AWAKENS A MAGNETIC FORCE THAT PULLS YOU IN, SLOWS YOU DOWN AND COMPELS YOU TO SAVOR THE MOMENT. WITH 56 MODULAR PIECES, THIS SOFA METAMORPHOSES INTO THE NATURAL CENTER OF GRAVITY IN ANY SPACE. HIGH-DENSITY POLYURETHANE CUSHIONS REST AGAINST A SCULPTURAL BOLSTER BACK, LURING YOU INTO A MALLEABLE COCOON OF SOFTNESS. RESISTANCE IS FUTILE—SINK BACK AND LET YOUR FINGERS FOLLOW THE EXQUISITE STITCHES TRACING THE ARMRESTS AND PADDING. VELAR'S MAGNETISM EXTENDS BEYOND TOUCH, LENDING MODERN REFINEMENT TO THE INTERIOR AND CREATING AN ELEGANT POINT OF ATTRACTION.





VESPER | DESIGN ATELIER D.O.

LOUNGE CHAIR 2025

FRAME: HAIRLINE STAINLESS STEEL (ANTIQUE GRAY) AND THICK LEATHER (ECRU)

SEAT AND BACK: FABRIC

| NEW |



AS DUSK SETTLES, VESPER EMERGES. INSPIRED BY THE GREEK MYTH OF THE EVENING STAR, THIS LOUNGE CHAIR OFFERS A PEACEFUL REFUGE. LEAN BACK AND LET THE CRESCENT CURVE OF THE UPHOLSTERED BACKREST ENVELOP YOU. BEFORE YOU KNOW IT, YOUR FINGERS WILL BE TRACING THE THICK, HANDWOVEN LEATHER STITCHES ALONG THE ARMRESTS, SEAMLESSLY FLOWING INTO THE STAINLESS STEEL FRAME. VESPER WILL SHINE IN ANY AMBIANCE: TAILOR IT TO YOUR INTERIOR BY CHOOSING FROM BLACK OR SIX STAINLESS STEEL FINISHES, LEATHER OR FABRIC IN OVER 60 OPTIONS. TRUE TO RITZWELL'S PHILOSOPHY, THIS LOUNGE CHAIR IS DESIGNED TO BE LIVED WITH, TO AGE BEAUTIFULLY, TO EVOKE MEMORIES—LIKE THE EVENING STAR, ALWAYS RETURNING.





CONSTANTINO | DESIGN SHINSAKU MIYAMOTO

EASY CHAIR 2025

FRAME: OAK POLYURETHANE FINISH (MATTE WHITE) | SEAT AND BACK: LEATHER

ARM AND PIPING: THICK LEATHER (ECRU)

| NEW |



CONSTANTINO COMMANDS PRESENCE WITH STYLE, HOLDING YOU WITH THE POISE OF A GRACEFUL DANCE PARTNER. WHETHER IN SPACIOUS SETTINGS OR INTIMATE CORNERS, THIS EASY CHAIR BEGUILLES—INVITING YOU TO MELT INTO ITS PADDED EMBRACE. AND WHO CAN RESIST THE CHARM OF ITS LEG LINES FLOWING INTO THE EDGE-TO-EDGE CUSHIONS, ITS MODERN AESTHETICS SEAMLESSLY BLENDING WITH CLASSIC ELEMENTS? GLIDE ALONG THE DELICATE WOODEN FRAME AND THICK LEATHER ARMRESTS WHILE CONTEMPLATING YOUR VICTORIES. RECLINE AGAINST THE GENTLY CURVED BACKREST. MORE THAN A VISUAL STATEMENT OR A SENSORY DELIGHT, THE SEGMENTED DESIGN OF THE BACKREST STRENGTHENS THE FRAME, ENSURING ITS EMBRACE CRADLES YOU FOR YEARS TO COME. TRUE TO RITZWELL'S MISSION, CONSTANTINO IS DESIGNED TO GROW IN VALUE, BECOMING ONE WITH YOUR CHERISHED MEMORIES OVER TIME.



ARMCHAIR | 2024

FRAME: WALNUT POLYURETHANE FINISH (MATTE SOHBOKU)
SEAT AND BACK: FABRIC
ARM AND PIPING: THICK LEATHER (ECRU)



ARMCHAIR | 2024

FRAME: OAK POLYURETHANE FINISH (MATTE WHITE)
SEAT AND BACK: LEATHER
ARM AND PIPING: LEATHER



CONSTANTINO | DESIGN SHINSAKU MIYAMOTO

ARMCHAIR 2024

FRAME: WALNUT POLYURETHANE FINISH (MATTE SOHBOKU) | SEAT AND BACK: FABRIC

ARM AND PIPING: THICK LEATHER (ECRU)





A MODERN ARMCHAIR IN SOLID WALNUT OR OAK WOOD: TAPERED LEGS AND CURVED ARMRESTS ENRICHED WITH TWO CONTRASTING FINISHES IN LEATHER OR THICK LEATHER APPLIED WITH DIFFERENT SEAMS: HAND-STITCHED ON THE THICK LEATHER AND MACHINE-STITCHED IN THE LEATHER VERSION. THE BACKREST AND SEAT CUSHION ARE PADDED WITH LAYERS OF MATERIALS WITH DIFFERENT INTENSITIES TO EMPHASIZE ITS SHAPE AND STYLE. CONSTANTINO IS AVAILABLE IN ALL WOOD FINISHES COMBINED WITH UPHOLSTERY IN FABRIC OR LEATHER.

MT COFFEE TABLE | DESIGN SHINSAKU MIYAMOTO

COFFEE TABLE 2024

TABLE TOP: OAK POLYURETHANE FINISH (MATTE WHITE)

FRAME: HAIRLINE STAINLESS STEEL (SHINY HAIRLINE)

TABLE TOP: WALNUT POLYURETHANE FINISH (MATTE SOHBOKU)

FRAME: HAIRLINE STAINLESS STEEL (ANTIQUÉ GRAY)

archiproducts
AWARDS
2024 WINNER



COFFEE TABLE | 2024
TABLE TOP: OAK POLYURETHANE FINISH (MATTE WHITE)
FRAME: STEEL (BLACK)



COFFEE TABLE | 2024
TABLE TOP: WALNUT POLYURETHANE FINISH (MATTE SOHBOKU)
FRAME: HAIRLINE STAINLESS STEEL (ANTIQUÉ GRAY)

DESIGNED FOR CONVERSATION AND OFFERED IN A SQUARE OR RECTANGULAR SHAPE IN TWO DIFFERENT HEIGHTS, IT COMBINES A DELICATELY CURVED SOLID-WALNUT OR OAK TOP WITH A SLENDER CYLINDRICAL STEEL LEG, IN A NATURAL FINISH, GREY OR MATT BLACK VARNISH. IT IS AT ONCE HIGHLY CONTEMPORARY AND DEEPLY TRADITIONAL: THE LOWER VERSION REFLECTS THE YUKAZA JAPANESE FLOOR SEATING AND ITS DELICATE APPEARANCE INSPIRES NEW TYPES OF TOKONOMA, THE ALCOVES THAT DISPLAY A FAMILY'S MOST PRECIOUS ITEMS IN A TRADITIONAL JAPANESE HOME.





MERCURY | DESIGN SHINSAKU MIYAMOTO

LOUNGE CHAIR 2023

FRAME: HAIRLINE STAINLESS STEEL (SHINY BRONZE) | ARM AND BACK: THICK LEATHER (VINTAGE BROWN)

CUSHION: FABRIC

archiproducts
AWARDS
2023 WINNER



LOUNGE CHAIR | 2023
FRAME: HAIRLINE STAINLESS STEEL (ANTIQUE GRAY)
ARM AND BACK: THICK LEATHER (ECRU)
CUSHION: FABRIC



SEEN FROM BEHIND, THE SPACE BETWEEN ITS INCLINED BACKBOARD AND REAR LEGS CREATES A COMFORTABLE BLANK SPACE DESIGN. THE FRONT LEGS, SIDE BATTENS, REAR LEGS AND ARMS ARE ASSEMBLED IN STRAIGHT LINES, SLIGHTLY TILTED INWARD TO JOIN THE REAR LEGS AND THE BACKBOARD. THIS EXQUISITE BALANCE PROVIDES ITS UNIQUE SHAPE WITH A SOLID IMPRESSION, WHILE THE GENTLE ELLIPTIC CURVE OF THE ARMRESTS ADDS WARMTH TO ITS SOPHISTICATED LINES. THIS LOUNGE CHAIR EXUDES A FAINTLY SEDUCTIVE CHARM ALONG WITH AN AIRY LOOK AND PURE DESIGN.



GQ TABLE | DESIGN SHINSAKU MIYAMOTO

SIDE TABLE 2023

TABLE TOP: OAK POLYURETHANE FINISH (MATTE BLACK)

FRAME: THICK LEATHER (VINTAGE BROWN) WRAPPED HAIRLINE STAINLESS STEEL (SHINY BRONZE)



reddot winner 2024



THIS CANTILEVER SIDE TABLE IS MADE OF DIFFERENT MATERIALS: STAINLESS STEEL, THICK LEATHER AND WOOD. IT IS SMALL, LIGHT, EASY TO CARRY, AND PERFECTLY FITS EVERY SCENE. THE SIMPLE STRUCTURE OF ITS SLENDER STAINLESS-STEEL FRAME GIVES A MODERN IMPRESSION, WHILE THE DECORATIVE CURVED RIB, CUT OUT OF A THIN FLAT BAR, PRODUCES A CLASSICAL ATMOSPHERE. THE RIM, WHICH SERVES PRIMARILY TO ENHANCE STRUCTURAL STRENGTH, IS USED AS PART OF THE DESIGN. THE THICK LEATHER WOUND AROUND THE STAINLESS STEEL GRACES THIS UNIQUE FORM. TO BRING OUT THE BEAUTIFUL EXPRESSIONS OF THE THICK LEATHER THAT IS INTEGRATED WITH THE SLENDER STAINLESS-STEEL FRAME, WE DARED TO CHOOSE HAND SEWING FOR THE DELICATE PROCESS TO CONCEAL STITCHES AND GIVE A SHARP FINISHING.



SIDE TABLE | 2023
TABLE TOP: WALNUT POLYURETANE FINISH (MATTE GEN)
FRAME: THICK LEATHER (TERRACOTTA)
WRAPPED HAIRLINE STAINLESS STEEL (ANTIQUÉ GRAY)



VERSE | DESIGN SHINSAKU MIYAMOTO

LOUNGE CHAIR 2023

FRAME: WALNUT OIL FINISH AND THICK LEATHER (VINTAGE BROWN)

SEAT AND CUSHION: FABRIC



THE SHARP LOOK OF ITS BACK, UNIQUE TO THICK LEATHER, THE DIGNIFIED APPEARANCE OF ITS WOOD FRAME, AND THE SHAPE OF ITS SEATBACK WITH A BRACING AIR, PRODUCE A STately ATMOSPHERE. THE PRODUCT OF INGENUITY, IT ADDS SOFTNESS TO THE DESIGN WHILE OFFERING COMFORT FOR THE BACK. THE TAPERED LEGS, BATTENS AND ARMS GENERATE THE SLENDER WOOD FRAME. THE FORM OF THE FRONT ARMS, INSPIRED ON TRADITIONAL CLASSIC CHAIRS, NATURALLY MERGES INTO ITS MODERN SHAPE, PROVIDING DYNAMISM AND ADDING ELEGANCE TO THE ENTIRE DESIGN.



MO BRIDGE | DESIGN SHINSAKU MIYAMOTO

COUNTER STOOL 2023

FRAME: OAK POLYURETHANE FINISH (MATTE TAUPE GRAY)

BELT: THICK LEATHER (BLACK)



THE MO BRIDGE COLLECTION IS CHARACTERIZED BY ITS ROUNDED EDGE LINE, WHICH PRODUCES A RELAXING ATMOSPHERE, AND ALSO BY THE EXPRESSIVE CHARM THAT THICK LEATHER CREATES. NOW, THE NEW COUNTER STOOL HAS JOINED THE COLLECTION. IT HAS A SIMPLE STRUCTURE OF THE FRAME ASSEMBLED WITH METICULOUSLY CUT WOOD PARTS AND THICK LEATHER BELTS WOVEN ONTO THE SEAT. QUALITY MATERIALS SET OFF ITS BEAUTIFUL CLASSICAL FORM AND GIVE SIMPLE AND WARM FINISHING TOUCHES TO THE DESIGN. THE NATURAL APPEARANCE OF THE STOOLS LINED UP ALONG A COUNTER EXUDES PRESENCE, BUT IS NEVER TOO ASSERTIVE. THE CUSHIONING MATERIAL, WHICH FIT BENEATH THE THICK LEATHER BELTS, GUARANTEES COMFORT FOR A SHORT OR LONG TIME. THE SIMPLE FORM OF THIS SUPERB STOOL OFFERS EXCELLENT SITTING COMFORT ANY WAY YOU SIT.

MO BRIDGE | DESIGN SHINSAKU MIYAMOTO

SMALL DESK AND STOOL 2020

TABLE TOP: OAK POLYURETHANE FINISH (BLACK) AND THICK LEATHER (VINTAGE BROWN)

FRAME: OAK POLYURETHANE FINISH (BLACK) | BELT: THICK LEATHER (VINTAGE BROWN)





BENCH | 2021
FRAME: WALNUT OIL FINISH
BELT: THICK LEATHER (TAUPE GRAY)



BENCH | 2021
FRAME: OAK POLYURETHANE FINISH (MATTE BLACK)
BELT: THICK LEATHER (BLACK)



THE MO BRIDGE COLLECTION IS CHARACTERIZED BY ELEGANCE AND SOPHISTICATION, WITH ITS SOFT LINES AND COMBINATIONS OF QUALITY MATERIALS. ANCIENT CRAFTSMANSHIP MERGES WITH MINIMAL SHAPES TO GENERATE THE CONTEMPORARY ESSENCE OF THESE PIECES. MO BRIDGE BENCH AND SQUARE BENCH ARE CHARACTERIZED BY WOODEN STRUCTURE AS WELL AS BY THE SEAT WHICH PLAYS WITH A WEAVE MADE IN PRECIOUS LEATHER.



MT | DESIGN SHINSAKU MIYAMOTO

BENCH 2020

SEAT: WALNUT OIL FINISH | FRAME: HAIRLINE STAINLESS STEEL (ANTIQUÉ BRASS)

BELT: THICK LEATHER (TAUPE GRAY)



BENCH | 2020

SEAT: OAK POLYURETHANE FINISH (BLACK)

FRAME: HAIRLINE STAINLESS STEEL (ANTIQUÉ GRAY)

BELT: THICK LEATHER (TAUPE GRAY)



BENCH | 2020

SEAT: WALNUT OIL FINISH

FRAME: HAIRLINE STAINLESS STEEL (SHINY BRONZE)

BELT: THICK LEATHER (TAUPE GRAY)

THE MT BENCH OFFERS AN INTRICATE GAME OF WEAVES AND A COMBINATION OF QUALITY MATERIALS THAT REPRESENT THE ENCOUNTER BETWEEN TRADITION AND MODERNITY. THE INTERWOVEN LEATHER STRAPS ON THE SEAT CONVEY A PLEASANT SENSATION OF WARMTH AND PERFECTLY MATCH THE STRUCTURE IN STEEL AND SOLID WALNUT OR OAK. THE ATTENTION TO DETAIL, SUCH AS THE PURE LINES AND ROUNDED EDGES OF THE SURFACE, MAKES THIS STRUCTURE A HARMONISING ELEMENT IN ANY ENVIRONMENT. THE BENCH IS AVAILABLE IN DIFFERENT COLOUR COMBINATIONS AND IN TWO SIZES.

RIVAGE | DESIGN ATELIER D.O.
EASY CHAIR 2011
FRAME: WALNUT OIL FINISH | SEAT AND BACK: LEATHER



ARMCHAIR | 2011
FRAME: WALNUT OIL FINISH
SEAT AND BACK: LEATHER



EASY CHAIR | 2016
FRAME: WALNUT OIL FINISH
SEAT AND BACK: LEATHER



STOOL | 2016
FRAME: OAK POLYURETHANE FINISH (BLACK)
SEAT: LEATHER

RIVAGE HAND STITCH | DESIGN ATELIER D.O
ARMCHAIR, EASY CHAIR, LOUNGE CHAIR 2022



ALL THE ARMCHAIRS IN THE RIVAGE COLLECTION CAN BE EMBELLISHED BY ELEGANT HAND-STITCHED SEAMS RUNNING ALONG THE ENTIRE EDGE OF THE SEAT'S BODY. THE USE OF NEEDLE AND THREAD REPRESENTS THE CULMINATION OF THE METICULOUS WORK THAT RITZWELL'S CRAFTSMEN DEDICATE TO EACH PRODUCT AS THEY TRANSFORM IT INTO A UNIQUE OBJECT. THUS, THE COMFORT AND BEAUTY AIMED FOR IN THE DESIGN OF THE SHAPE AND THE SELECTION OF PRECIOUS MATERIALS ARE FURTHER ENHANCED BY THE PATTERN GENERATED BY THE STITCHING, WHICH CONVEYS THE "MEMORY OF THE HANDS" THAT CREATED EACH DETAIL.

RIVAGE | DESIGN ATELIER D.O.
METAL ARMCHAIR 2023
FRAME: HAIRLINE STAINLESS STEEL (ANTIQUE GRAY)
ARM: WALNUT OIL FINISH | SEAT AND BACK: LEATHER



METAL ARMCHAIR | 2023
FRAME: HAIRLINE STAINLESS STEEL (ANTIQUE GRAY)
ARM: OAK POLYURETHANE FINISH (MATTE BLACK)
SEAT AND BACK: FABRIC



THE RIVAGE COLLECTION HAS A SERENE BEAUTY THAT COMES FROM ITS FORM INSPIRED BY THE CURVED BLADE OF A JAPANESE SWORD. SUBLIMATING THE JAPANESE ANCIENT AESTHETIC SENSE INTO FORMATIVE ART THAT IS HIGHLY VALUED EVEN IN THE PRESENT DAY, THIS COLLECTION IS ONE OF RITZWELL'S MASTERPIECES. IN THE ARMCHAIR THE COMBINATION OF WOOD AND A DIFFERENT MATERIAL FOR THE FRAME GIVES A COMFORTABLE TENSE AND AIRINESS TO THIS CHAIR SEAT. THE SIMPLE AND RELAXING ARMRESTS, WITH THEIR GENTLE AND WARM NATURE OF WOOD, COMFORTABLY SUPPORT YOUR ARMS AND MAKE YOU FEEL CALM AND AT EASE, WHICH ARE FEATURES NECESSARY FOR ANY CHAIR.

RIVAGE | DESIGN ATELIER D.O.

LOUNGE CHAIR 2020

FRAME: STEEL (BLACK) | ARM: WALNUT OIL FINISH | SEAT AND BACK: LEATHER

| 43



THE RIVAGE LOUNGE CHAIR IS COMPOSED BY A STEEL STRUCTURE WHICH IS COMBINED WITH A SOFT SEAT. THE CONTEMPORARY AND APPEALING DESIGN OF THIS PRODUCT CONVEYS A SENSE OF CALM, RELAXATION, SOLIDITY AND SAFETY. THE COMFORTABLE ARMRESTS IN WALNUT OR OAK DRAW INSPIRATION FROM THE TYPICAL CURVED SHAPE OF THE ROOFS OF JAPANESE TEMPLES AND SHRINES. THANKS TO THE VARIOUS FINISHES AND SHADES AVAILABLE, THE RIVAGE ARMCHAIR FITS PERFECTLY INTO ANY LIVING SPACE.

MTM TABLE | DESIGN SHINSAKU MIYAMOTO

DINING TABLE 2023

TABLE TOP: OAK POLYURETHANE FINISH (MATTE BLACK)

FRAME: HAIRLINE STAINLESS STEEL (ANTIQUÉ GRAY)



JK | DESIGN JUN KAMAHARA

EASY CHAIR 2019

FRAME: HAIRLINE STAINLESS STEEL (CLASSIC ROSE) AND LEATHER (BLACK)

SEAT AND BACK: THICK LEATHER (BLACK) | CUSHION: LEATHER



THE JK EASY CHAIR IS COMPOSED BY A THIN TUBULAR FRAME IN STAINLESS STEEL SUPPORTING A DEEP LEATHER SEAT. THE BACKREST IS MADE OF LEATHER STRIPS PADDED WITH LARGE CUSHIONS WHICH HAVE BEEN SPECIFICALLY DESIGNED TO DELICATELY HOST THE PERSON'S HIPS AND PROVIDE A COMFORTABLE SUPPORT FOR THE BACK. THE COMFORT GRANTED BY THIS CHAIR IS ALMOST SURPRISING CONSIDERING THE HIGHLY GRAPHIC APPEARANCE OF THE OBJECT. ALL THE MATERIALS AND FINISHES HAVE BEEN CHOSEN FOR THEIR CAPACITY TO BECOME MORE BEAUTIFUL SEASON AFTER SEASON AND ACQUIRE THE FAMOUS "GLAZE OF TIME" (FURUBI IN JAPANESE).

JK HAND STITCH | DESIGN JUN KAMAHARA

EASY CHAIR 2022

FRAME: HAIRLINE STAINLESS STEEL (SHINY BRONZE) AND LEATHER (BLACK)

SEAT AND BACK: THICK LEATHER (BLACK) | CUSHION: FABRIC AND LEATHER PIPING



THIS REEDITION, PRESENTED ON THE OCCASION OF THE BRAND'S 30TH ANNIVERSARY, EMPLOYS HIGH-QUALITY MATERIALS THAT ARE FURTHER ENHANCED BY REFINED HAND-CRAFTED WORKMANSHIP. THE BACKREST IS CHARACTERISED BY A GENEROUS CUSHION IN FABRIC AND DIALOGUES WITH THE SLIM LEATHER SEAT, WHICH IS EMBELLISHED BY PROMINENT HAND STITCHING. THE LEATHER ENVELOPS THE METAL STRUCTURE ON BOTH SIDES OF THE SEAT AND GIVES RISE TO A CLEAN AND DETERMINED DESIGN CAPABLE OF ENSURING A HIGH LEVEL OF COMFORT.

CLAUDE | DESIGN SHINSAKU MIYAMOTO

EASY CHAIR 2013

FRAME: WALNUT OIL FINISH

SEAT AND BACK: LEATHER

THE DETAILING ON THE SCULPTURED ARMRESTS AND THE LINES OF THE LEGS ARE UNIQUE, AND ESPECIALLY THE FLAWLESS CARVING OF THE ARMRESTS SUGGESTS THE ANCIENT STATUES OF BUDDHA, CREATING A TOOLED YET EVEN FINISH. THE POWERFUL DESIGN ENCOMPASSES TRANQUILITY AND QUIETUDE... A DESIGN THAT COMBINES OLD ELEMENTS INTO SOMETHING STUNNINGLY NEW.



CHAIR | 2016
FRAME: OAK OIL FINISH (WHITE)
SEAT AND BACK: LEATHER



ARMCHAIR | 2013
FRAME: WALNUT OIL FINISH
SEAT AND BACK: FABRIC



EASY CHAIR | 2016
FRAME: OAK POLYURETHANE FINISH (MATTE BLACK)
SEAT AND BACK: LEATHER



CHAIR | 2016

FRAME: OAK OIL FINISH (WHITE)
BACK PANEL: OAK POLYURETHANE FINISH (BLACK)
SEAT AND BACK: LEATHER



CHAIR | 2013

FRAME: WALNUT OIL FINISH
BACK PANEL: WALNUT POLYURETHANE FINISH
SEAT AND BACK: LEATHER



CHAIR | 2016

FRAME: OAK POLYURETHANE FINISH (MATTE BLACK)
BACK PANEL: OAK POLYURETHANE FINISH (MATTE BLACK)
SEAT AND BACK: LEATHER

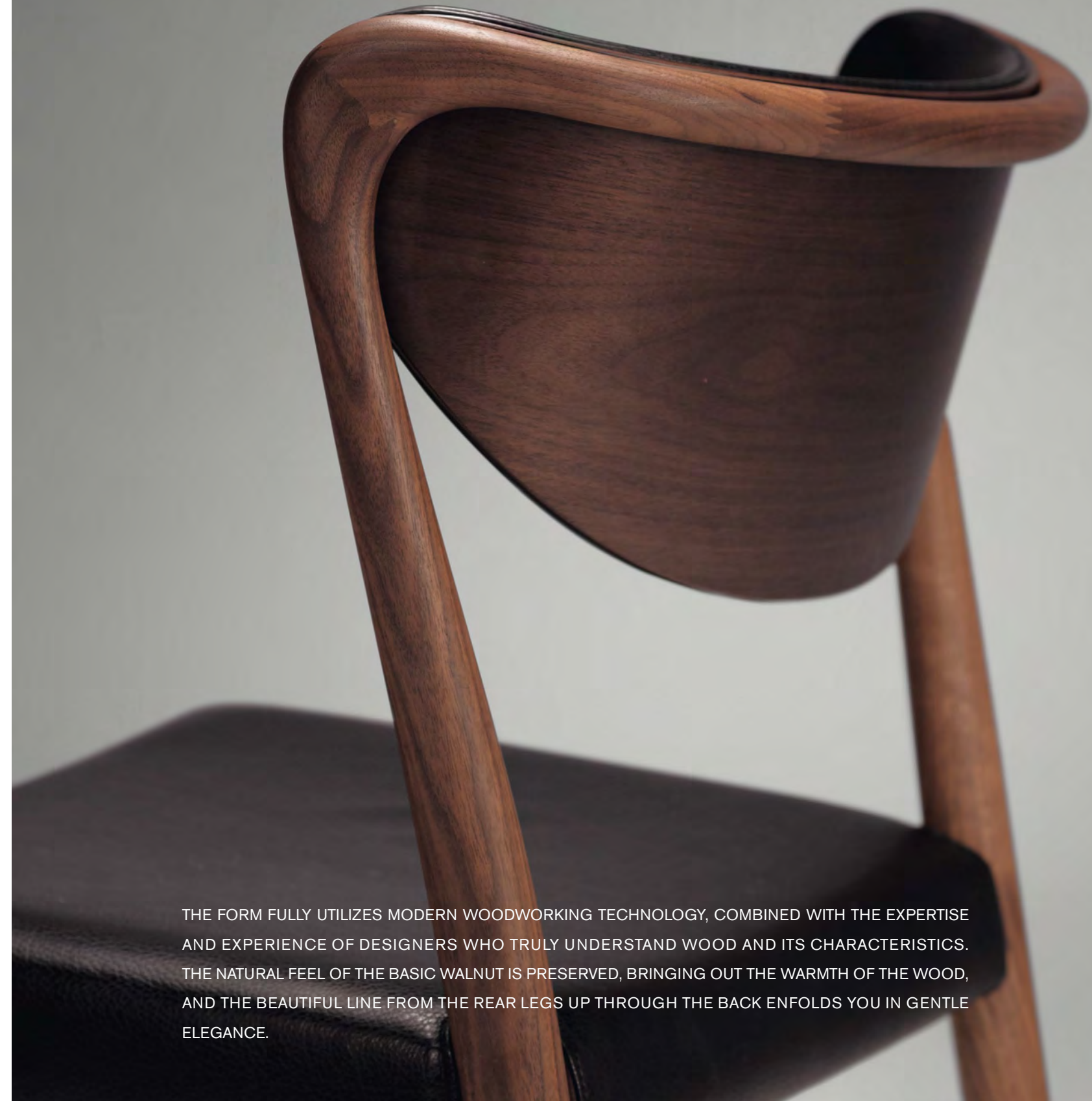

THE FORM FULLY UTILIZES MODERN WOODWORKING TECHNOLOGY, COMBINED WITH THE EXPERTISE AND EXPERIENCE OF DESIGNERS WHO TRULY UNDERSTAND WOOD AND ITS CHARACTERISTICS. THE NATURAL FEEL OF THE BASIC WALNUT IS PRESERVED, BRINGING OUT THE WARMTH OF THE WOOD, AND THE BEAUTIFUL LINE FROM THE REAR LEGS UP THROUGH THE BACK ENFOLDS YOU IN GENTLE ELEGANCE.

LUPIN | DESIGN ATELIER D.O.

LOUNGE CHAIR 2014

FRAME: WALNUT OIL FINISH AND THICK LEATHER (BLACK) | PADDING AND CUSHION: LEATHER



THE SQUARE FORM OF THE SOFA IMPARTS A FEELING OF RELAXATION AND COMFORT. WHILE COMPOSED OF FLAT SURFACES ON THREE SIDES IT EVOLVES INTO A THREE-DIMENSIONAL FORM RICH IN ORGANIC BEAUTY. THE LUXURIOUS BASE OF THICK LEATHER IS ACCENTUATED WITH A BELT DESIGN BRINGING OUT THE FULL BEAUTY OF THE MATERIALS. THE INTERPLAY OF LIGHT AND SHADOW ON THE DELICATE TEXTURE REVEALS ITS QUIET, REFINED FEEL. ALVAR AALTO ONCE SAID, "THE FURNITURE, THE FABRICS, THE COLOR SCHEMES AND THE STRUCTURES CAN BE EARNESTLY AND HAPPILY MADE SO THAT THEY PRODUCE NO CONTRAST TO THE TRAGEDY AND COMEDY OF HUMAN LIFE". AND IN KEEPING WITH HIS PHILOSOPHY OUR SOFA INCORPORATES SOFTNESS INTO ITS VERY DESIGN FOR SATISFYINGLY DEEP COMFORT AND RELAXATION.

JK | DESIGN JUN KAMAHARA

ARMCHAIR 2004

FRAME: WALNUT OIL FINISH | SEAT: LEATHER | BACK: THICK LEATHER (BLACK)

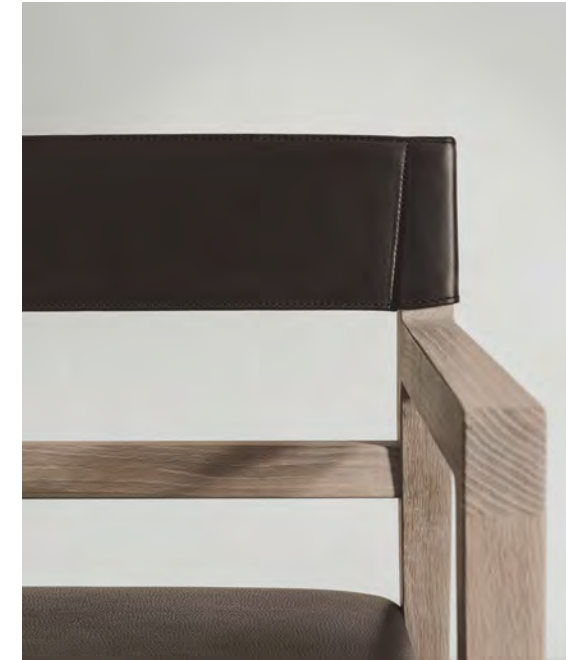

DETAIL | ARMCHAIR | 2016

FRAME: OAK OIL FINISH (WHITE)

SEAT: LEATHER

BACK: THICK LEATHER (BLACK)



BLAVA | DESIGN ATELIER D.O.

EASY CHAIR 2007

FRAME: WALNUT OIL FINISH | CUSHION: LEATHER | BELT: THICK LEATHER (BLACK)



DETAIL | EASY CHAIR | 2016

FRAME: WALNUT OIL FINISH
CUSHION: FABRIC
BELT: THICK LEATHER (BLACK)

EASY CHAIR | 2016

FRAME: OAK OIL FINISH (WHITE)
CUSHION: LEATHER
BELT: THICK LEATHER (BLACK)





STOOL | 2024
FRAME: WALNUT POLYURETHANE FINISH (MATTE GEN)
BELT: THICK LEATHER (TERRACOTTA)



STOOL | 2016
FRAME: OAK POLYURETHANE FINISH (BLACK)
BELT: THICK LEATHER (BLACK)



STOOL | 2016
FRAME: OAK OIL FINISH (WHITE)
BELT: THICK LEATHER (BLACK)

VINCENT | DESIGN RITZWELL
STOOL 2016
FRAME: WALNUT POLYURETHANE FINISH (MATTE GEN)
BELT: THICK LEATHER (TERRACOTTA)

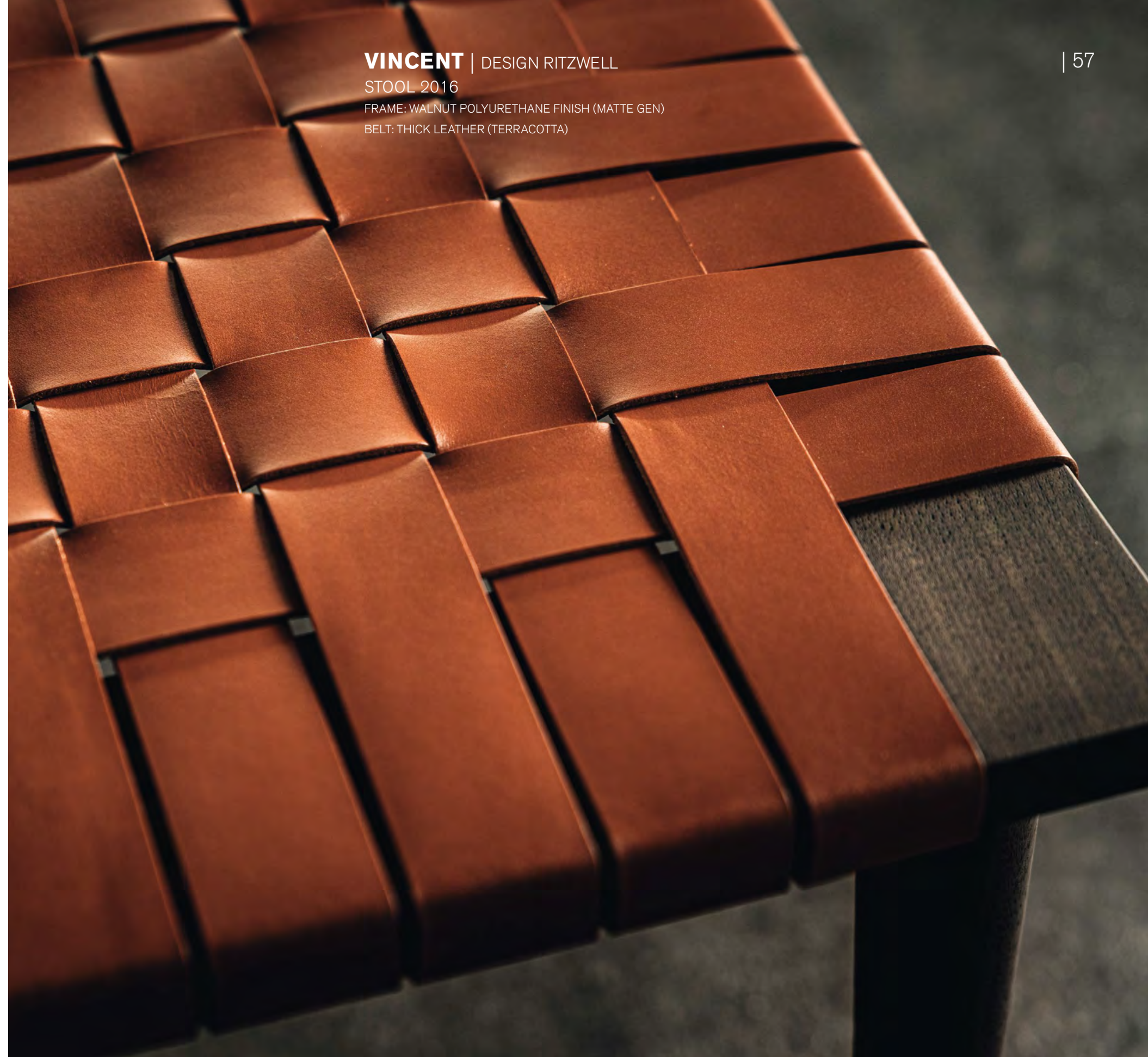

JABARA | DESIGN SHINSAKU MIYAMOTO

SIDEBOARD 2018

BODY: OAK POLYURETHANE FINISH | BASE: HAIRLINE STAINLESS STEEL (SHINY BRONZE)

FRONT DRAWER: THICK LEATHER | DOOR: SLIDING TAMBOUR DOOR



SIDEBOARD | 2018

BODY: OAK POLYURETHANE FINISH (MATTE WHITE)

BASE: STEEL (BLACK)



SIDEBOARD | 2018

BODY: WALNUT POLYURETHANE FINISH

BASE: STEEL (BLACK)



SIDEBOARD | 2018

BODY: WALNUT POLYURETHANE FINISH

BASE: STEEL (BLACK)



THE JABARA SIDEBOARD USES DISTINCTIVE SLIDING TAMBOUR DOORS IN A MODERN, MINIMALIST FORM. THE FEELING OF UNEVENNESS THAT COMES FROM SOLID WOOD THAT HAS BEEN CUT OFF INTO THIN STRIPS AND GIVEN A ROUNDED SURFACE, AND THE SENSIBILITY OF THE CRAFTSMAN IN DISCERNING THE ESSENTIAL NATURE OF THE SOLID WOOD, COMBINE TO GIVE RISE TO MAGICAL SHADOWS AND A WARM, PROFOUND EXPRESSIVENESS IN THE ENTIRE PRODUCT. THICK LEATHER WITH A NATURAL TEXTURE, PAINSTAKINGLY TANNED USING VEGETABLE TANNIN, IS USED ON THE SURFACE OF THE DRAWERS. THE LEATHER COMPLEMENTS THE LUXURIOUSNESS AND PLEASURE OF THE PRODUCT AS A WHOLE.

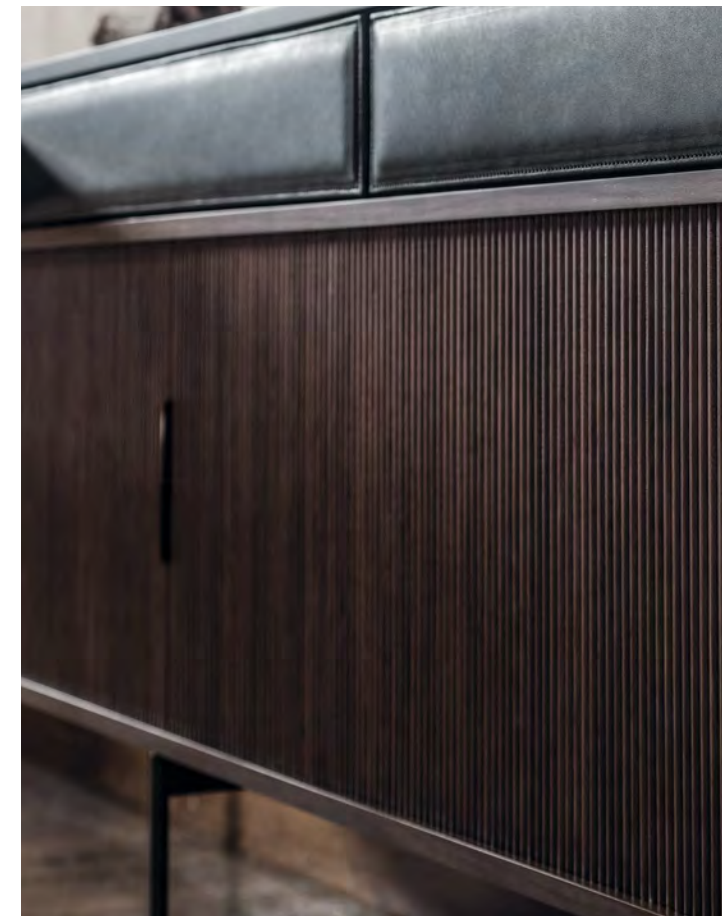



JABARA | DESIGN SHINSAKU MIYAMOTO

AV BOARD 2019

BODY: OAK POLYURETHANE FINISH (MATTE WHITE)

BASE: STEEL (BLACK) | DOOR: SLIDING TAMBOUR DOOR AND GLASS FLAP DOOR



best of the best 2019



JABARA AV BOARD IS A CABINET FOR AUDIO-VISUAL EQUIPMENT CONCEIVED TO ELEGANTLY AND FLEXIBLY INSERT ITSELF INTO THE CONTEMPORARY HOME THANKS TO ITS MANY VARIATIONS IN SIZE AND STRUCTURE. ONE OR SEVERAL STORAGE COMPARTMENTS FEATURING TAMBOUR WOODEN DOORS ARE ALTERNATED WITH AN AREA DESIGNED FOR TECHNOLOGICAL COMPONENTS. THE LATTER, WHICH IS IDENTIFIED BY A TILT AND TURN DOOR IN DARK TINTED GLASS, INTRODUCES A STRONG COMPOSITIONAL ELEMENT WHICH - BY CONTRAST - HIGHLIGHTS THE JAPANESE AESTHETICS OF THE SLIM VERTICAL LINES OF THE TAMBOUR DOORS, TYPICAL OF THE YOSHIDO CANE DOORS AND THE SAGANO BAMBOO FORESTS IN KYOTO.



AV BOARD | 2019
BODY: OAK POLYURETHANE FINISH (MATTE WHITE)
BASE: WOOD (BLACK)



AV BOARD | 2019
BODY: WALNUT POLYURETHANE FINISH
BASE: STEEL (BLACK)



AV BOARD | 2019
BODY: OAK POLYURETHANE FINISH (MATTE WHITE)
BASE: STEEL (BLACK)

OS TABLE | DESIGN RITZWELL

SIDE TABLE 2014

TABLE TOP: WALNUT OIL FINISH

LEG: HAIRLINE STAINLESS STEEL (SHINY BRONZE)



SIDE TABLE | 2016

TABLE TOP: OAK POLYURETHANE FINISH (BLACK)

LEG: STEEL (BLACK)



SIDE TABLE | 2016

TABLE TOP: OAK OIL FINISH (WHITE)

LEG: STEEL (BLACK)



COFFEE TABLES | 2004
TABLE TOP: WALNUT OIL FINISH
LEG: STEEL (BLACK)

JK TABLE | DESIGN JUN KAMAHARA

COFFEE TABLE 2004

TABLE TOP: WALNUT OIL FINISH | LEG: HAIRLINE STAINLESS STEEL (SHINY BRASS)





SIDE TABLE | 2019
TABLE TOP: WALNUT OIL FINISH
LEG: HAIRLINE STAINLESS STEEL (ANTIQUÉ BRASS)



SIDE TABLE | 2019
TABLE TOP: WALNUT OIL FINISH
LEG: HAIRLINE STAINLESS STEEL (SHINY BRONZE)

AVAILABLE IN TWO VERSIONS, WITH A SQUARED AND CIRCULAR TOP, JK SIDE TABLES ARE CHARACTERISED BY A PARTICULAR LIGHTNESS THANKS TO THE SLIM SECTION OF THE TOP IN SOLID WALNUT AND THE STEEL POWDER COATING STRUCTURE AND HAIRLINE STAINLESS STEEL ACRYLIC URETHANE COATING STRUCTURE. THEIR MINIMALIST DESIGN IS EMBELLISHED BY THE SLIGHTLY UPWARD CURVING CORNERS OF THE SQUARED TOP AND BY THE BEVELLED EDGE OF THE CIRCULAR VERSION.

MO TABLE | DESIGN SHINSAKU MIYAMOTO
DINING TABLE 2016
TABLE TOP AND LEG: OAK POLYURETHANE FINISH (BLACK)



DINING TABLE | 2016
TABLE TOP AND LEG: OAK POLYURETHANE FINISH (BLACK)



SIDE TABLE | 2016
TABLE TOP AND LEG: OAK OIL FINISH (WHITE)



COFFEE TABLE | 2016
TABLE TOP AND LEG: OAK POLYURETHANE FINISH (BLACK)

THESE TABLES BRING A WARM, GENTLE FEELING TO EVERY SCENE, WITH DELIGHTFUL LEG LINES, THE STRENGTH OF SOLID WOOD SHINES THROUGH IN THIS MODERN DESIGN. THE QUALITY LOOK AND FEEL OF NATURAL WOOD BRINGS TRANQUILLITY. THE COLLECTION COMBINES TWO TYPES OF DINING TABLE WITH ROUNDED OR RECTANGULAR TOP WITH A NUMBER OF ROUND COFFEE AND SIDE TABLES TO CREATE INFINITE NOOKS AND GATHERINGS.

MO TABLE | DESIGN SHINSAKU MIYAMOTO

DINING TABLE 2021

TABLE TOP: WALNUT OIL FINISH

LEG: OAK POLYURETHANE FINISH (BLACK)

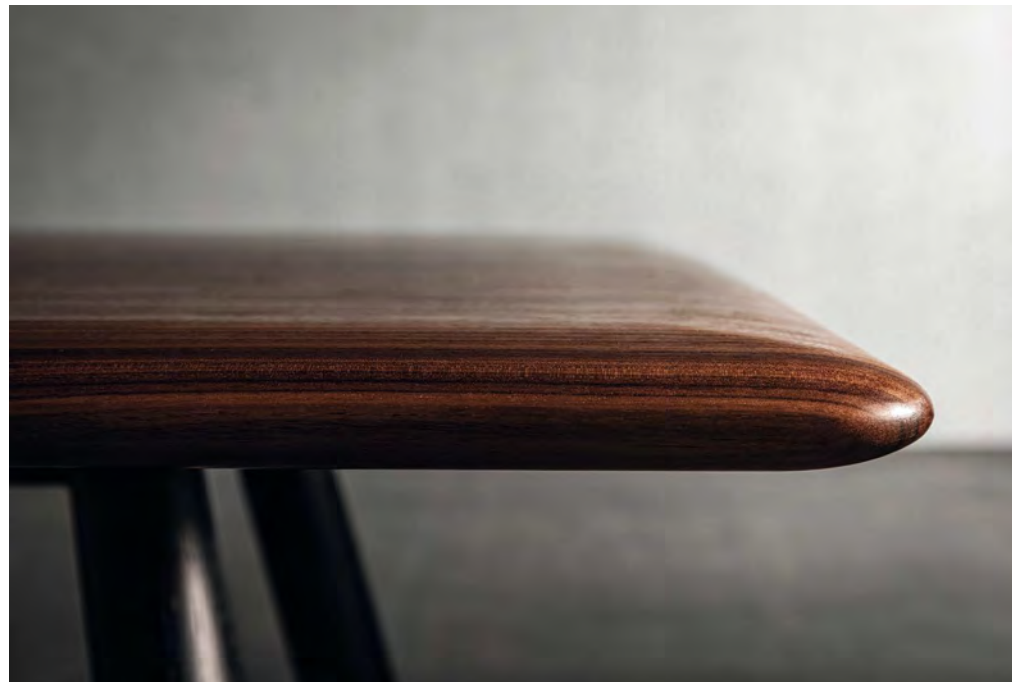

MCM TABLE | DESIGN SHINSAKU MIYAMOTO

DINING TABLE 2015

TABLE TOP AND LEG: WALNUT OIL FINISH | FRAME: STEEL (BLACK)



ONLY SUPPORTED BY FOUR LEGS, ITS SIMPLE DESIGN HIGHLIGHTS THE THINNESS OF THE TABLE TOP. THIS SUPERB, MODERN LOOKING LONG SIZE TABLE COMBINES STRENGTH AND DESIGNABILITY. ITS DETAILED DESIGN, WHICH ADDS TO THE WONDERFUL APPEARANCE AND ROUNDNESS OF A WOOD GRAIN TABLE TOP THAT CAN ONLY BE CREATED WITH NATURAL WOOD, ALSO ALLOWS ONE TO FEEL THE STRONG PRESENCE AND GENTLENESS THAT WOOD POSSESSES, AS WELL AS BRINGING A BEAUTIFUL BALANCE TO COMFORTABLE, RELAXING SPACES.



MT TABLE | DESIGN SHINSAKU MIYAMOTO

DINING TABLE 2021

TABLE TOP: WALNUT OIL FINISH | FRAME: HAIRLINE STAINLESS STEEL (ANTIQUE GRAY)

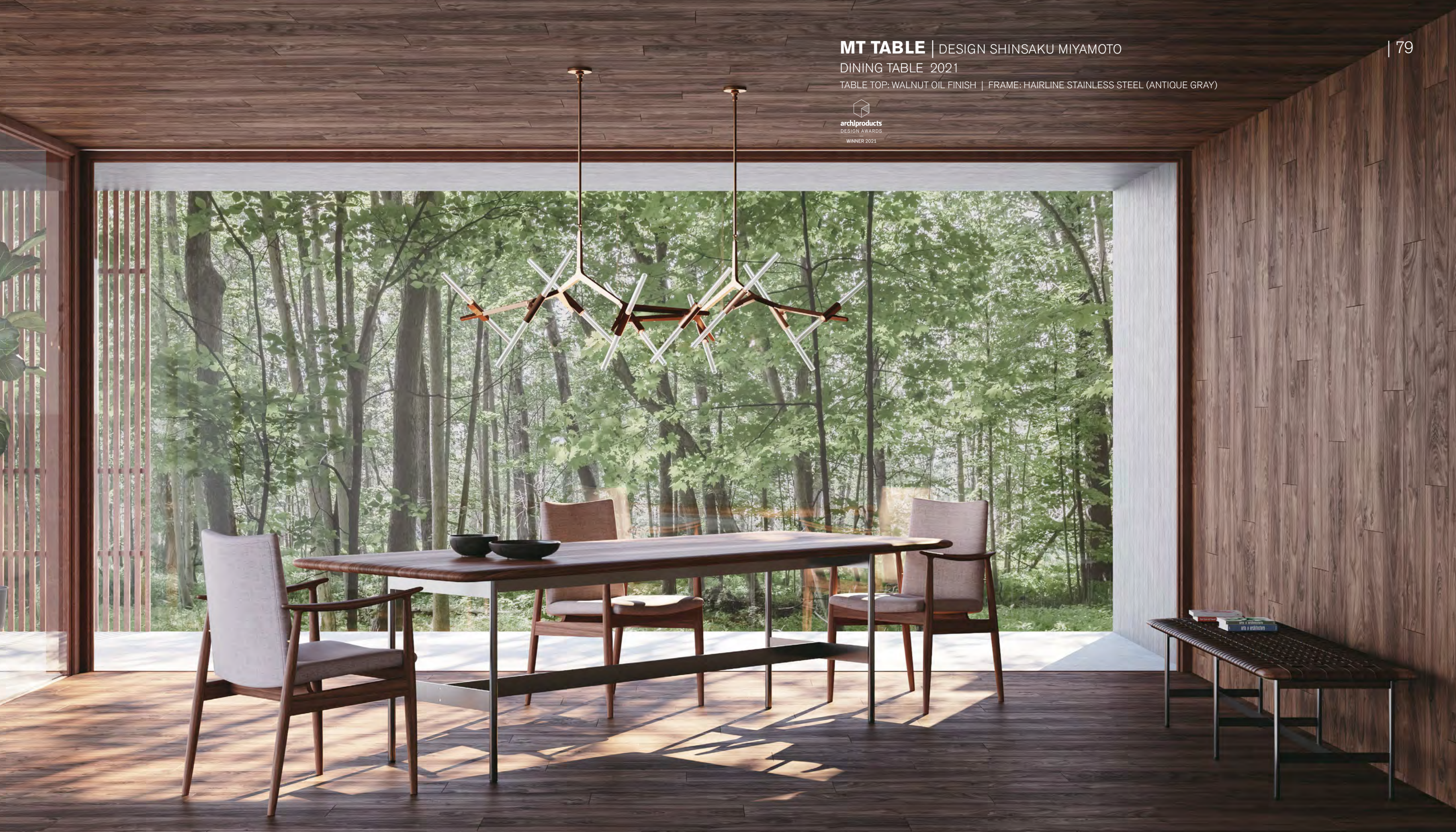

MODULAR SOFA 2021

FRAME: WHITE ASH POLYURETHANE FINISH (BLACK)

CUSHION: FABRIC



1 SEATER SOFA | 2021

FRAME: WHITE ASH POLYURETHANE FINISH (BLACK)

CUSHION: FABRIC



OTTOMAN | 2021

FRAME: WHITE ASH POLYURETHANE FINISH (BLACK)

CUSHION: FABRIC



SIDE TABLE | 2021

TOP: OAK POLYURETHANE FINISH (BLACK)

LEG FRAME: WHITE ASH POLYURETHANE FINISH (BLACK)



3 SEATER SOFA | 2021

FRAME: WHITE ASH POLYURETHANE FINISH (BLACK)

CUSHION: FABRIC



THIS MODULAR SOFA FEATURES A LOW SEAT AS A REFERENCE TO THE WAY JAPANESE PEOPLE SIT ON THE TATAMI AND IS MADE PARTICULARLY COMFORTABLE BY THE SOFT AND LARGE CUSHIONS PLACED DELICATELY ON THE MODERN STRUCTURE, WHICH IS ENTIRELY MADE IN SOLID ASH. THE BACKREST AND ARMRESTS DEFINE A PARTICULARLY APPEALING STYLISTIC DETAIL. IT SPRINGS FROM A TIDY JUXTAPOSITION OF THIN WOODEN STAVES THAT SHAPE A GRID, WHICH IS A DECORATIVE AND FUNCTIONAL ELEMENT ALL AT ONCE.

BEATRIX | DESIGN SHINSAKU MIYAMOTO
HIGH BACK EASY CHAIR 2017 AND OTTOMAN 2018

FRAME: WALNUT OIL FINISH | SEAT AND BACK: FABRIC | SHELL: THICK LEATHER (VINTAGE BROWN)



reddot design award
winner 2019



CONSISTING OF A VARIETY OF ELEMENTS, THE BEATRIX HIGH-BACK EASY CHAIR WAS DEVELOPED OVER MANY YEARS OF EXPERIMENTATION, ON THE BASIS OF THE AESTHETIC SENSIBILITIES AND SUPERIOR TECHNOLOGICAL PROWESS OF JAPAN. THE EXCEPTIONAL CONSCIENTIOUSNESS AND ATTENTION TO DETAIL OF JAPANESE CRAFTSPEOPLE ARE NECESSARY FOR THE CHAIR'S PRODUCTION. ALTHOUGH THIS CHAIR IS NOT SUITED TO MASS PRODUCTION, IN ORDER TO MAKE SOMETHING THAT RESONATES WITHIN THE HEART OF THE USER, WE BELIEVE IT IS ESSENTIAL TO MAKE THAT ITEM BY HAND, ONE BY ONE, WITH LOVING CARE.



HIGH BACK EASY CHAIR | 2017

FRAME: WALNUT OIL FINISH
SEAT AND BACK: LEATHER
SHELL: THICK LEATHER (BLACK)



HIGH BACK EASY CHAIR | 2020

FRAME: WALNUT OIL FINISH
SEAT AND BACK: FABRIC
SHELL: FABRIC
PIPING: LEATHER



HIGH BACK EASY CHAIR | 2017 AND OTTOMAN | 2018

FRAME: WALNUT POLYURETHANE FINISH (MATTE SOHBOKU)
SEAT AND BACK: FABRIC
SHELL: THICK LEATHER (ECRU)



LIGHT FIELD | DESIGN SHINSAKU MIYAMOTO

MODULAR SOFA 2014

FRAME: FABRIC, LEATHER AND THICK LEATHER COVERED PANELS

PADDING AND CUSHION: FABRIC AND LEATHER

LEG: HAIRLINE STAINLESS STEEL



THE LUXURIOUS CUSHION ENSURES RELAXATION, WHILE THE STRIKING LEATHER FORM IS LIGHT, AIRY. THIS EXQUISITE PIECE OFFERS A DELICATE BALANCE OF QUIETUDE AND TENSION. THE THICK LEATHER IS PREPARED WITH TANNIN TO BRING OUT ITS FULL BEAUTY, AND STITCHED WITH CARE TO LEVERAGE THE QUALITY OF THE HIGH-GRADE MATERIALS INTO A MASTERPIECE OF UNDERSTATEMENT. FABRIC CUSHIONS ENFOLD YOU IN COMFORT, ADDING SOFTNESS TO THE WHOLE AND REALIZING A BOLD AND ELEGANT ADDITION TO YOUR ROOM.



DETAIL | 3 SEATER SOFA | 2014
FRAME: THICK LEATHER COVERED PANELS (AMBER)
PADDING AND CUSHION: FABRIC



3 SEATER SOFA | 2014
FRAME: THICK LEATHER COVERED PANELS (AMBER)
PADDING AND CUSHION: FABRIC
LEG: HAIRLINE STAINLESS STEEL (ANTIQUÉ GRAY)



DIANA | DESIGN SHINSAKU MIYAMOTO

1 SEATER SOFA 2015

FRAME: WALNUT OIL FINISH | FRAME COVER: LEATHER | CUSHION: LEATHER



1 SEATER SOFA | 2015
FRAME: WALNUT OIL FINISH
FRAME COVER AND CUSHION: LEATHER

THE CHARACTERISTIC LINE OF THE BACK AND ARM FRAME, CURVING TO ENCOMPASS YOUR BODY, GIVES THE DESIGN A POWERFUL VISUAL IMPACT COMBINED WITH THE UNIQUE TRANQUILITY OF JAPAN. THE LEATHER WRAPPINGS ON THE FRAME ADJUST THE FEEL OF THE WOOD, BRINGING ITS WILD NATURE UNDER CONTROL AND CAMOUFLAGING ITS FORM TO MAKE THE WALNUT STAND OUT EVEN MORE. THE HUES OF THE LEATHER ARE AS CLOSE TO NATURAL AS POSSIBLE, BALANCING WELL WITH THE WALNUT AS NO INORGANIC, UNIFORM COLOR COULD. THE FUSION OF WALNUT AND LEATHER CREATES A HIGH-GRADE FEEL, AND EXPRESSES THE AMBIANCE OF JAPAN THROUGH WOOD, LEATHER AND CLOTH.



3 SEATER SOFA | 2013
FRAME: WALNUT OIL FINISH
FRAME COVER: LEATHER
CUSHION: FABRIC



3 SEATER SOFA | 2016
FRAME: OAK OIL FINISH (WHITE)
FRAME COVER AND CUSHION: LEATHER



OTTOMAN | 2016
FRAME: OAK OIL FINISH (WHITE)
FRAME COVER AND CUSHION: LEATHER



3 SEATER SOFA | 2013
FRAME: WALNUT OIL FINISH
FRAME COVER: LEATHER
CUSHION: FABRIC

CREATED BY THE HANDS OF JAPANESE ARTISANS

Every Ritzwell product encloses a deep thought aimed at generating wellbeing. An accurate design project outlines the shape, while the expert manual skill of our craftsmen transforms it with extreme care into a precious object where flawless execution is crucial. We produce furniture that not only responds to the needs of function and aesthetics, but also to the needs of the soul, which recognises their harmony and perceives the 'memory of the hands' that created every detail. We select only high-quality materials such as solid wood, leather, the softest hides, and most versatile natural fabrics. The metal structures are equipped with precious and resistant finishes made vibrant by a carefully studied colour range. Our main concern is making sure that every piece preserves its beauty season after season, as it acquires a fascinating furubi or 'patina of time' which makes items unique and conceived to be handed down from generation to generation.

QUALITY

Technology and craftsmanship coexist at Ritzwell: technology guarantees the best production methods and long-lasting products, while handcrafted finishings are an expression of the artisan skills found in haute couture workshops. As a result, the brand's appeal continues to grow among architects and interior designers, also because of its vast range of high-end projects for private dwellings and commercial spaces. Shinsaku Miyamoto and Atelier D.O. in their dual role of designers and art directors of the brand have always matched research into style with research into materials, which are must-haves in products of excellence. At the company-cum-workshop every product is a new, fundamental step in the company mission: to disseminate the aesthetic concept of beauty, in keeping with Japanese tradition, and to deliver a perfect example of design that is all about simple harmony, pure equilibrium and an unmistakable style.



ITOSHIMA SEASIDE FACTORY

Itoshima Seaside Factory is set in the heart of a pine forest overlooking the beauty of the Genkai Sea. This is the core of our manufacturing process, focused on hand worked upholstery and the sewing stage of production. In a time when cost and efficiency are commonly prioritized during manufacturing, we, instead, have chosen to value and spare no effort in our reliable creative process. The refined space of the building offers both functionality and a warm atmosphere and is built on a strong belief in the brand concept—that the aesthetic sensitivity and skills of trained craftspeople are cultivated if immersed in pleasant surroundings. Here young artisans earnestly create their unique pieces, making full use of the latest technology as well as of a strict hand-crafting process. Every day is spent in a top-quality and calm atmosphere, where people work and, at the same time, enjoy the scent of the sea carried by wind blowing through the trees, and the sound of waves rolling in on the sandy beach.



08 |

VESPER

Design: ATELIER D.Q.

Seat and back in fabric and leather
 Frame in steel powder coating with black and hairline stainless steel acrylic urethane coating with 6 colors, classic rose, shiny brass, antique brass, shiny bronze, antique gray and shiny hairline and in thick leather black, taupe gray, ecru, amber, terracotta, burgundy, vintage brown and dark brown



10, 13 |

CONSTANTINO

Design: SHINSAKU MIYAMOTO

Seat and cushion in fabric and leather
 Frame in walnut, oak
 Arm and piping in fabric, leather and thick leather black, taupe gray, ecru, amber, terracotta burgundy, vintage brown and dark brown

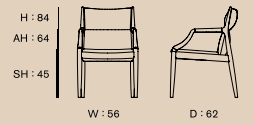

ARMCHAIR



EASY CHAIR

20 |

MERCURY

Design: SHINSAKU MIYAMOTO

Seat and cushion in fabric and leather
 Frame in steel powder coating with black and hairline stainless steel acrylic urethane coating with 6 colors, classic rose, shiny brass, antique brass, shiny bronze, antique gray and shiny hairline
 Arm and back in thick leather black, taupe gray, ecru, amber, terracotta, burgundy, vintage brown and dark brown

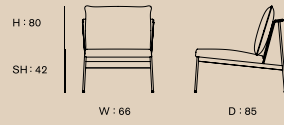

LOUNGE CHAIR

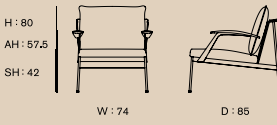

LOUNGE CHAIR

26 |

VERSE

Design: SHINSAKU MIYAMOTO

Seat and cushion in fabric and leather
 Frame in walnut, oak and thick leather black, taupe gray, ecru, amber, terracotta, burgundy, vintage brown and dark brown

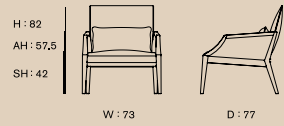

LOUNGE CHAIR

48 |

CLAUDE

Design: SHINSAKU MIYAMOTO

Seat and back in fabric and leather
 Frame in walnut, oak

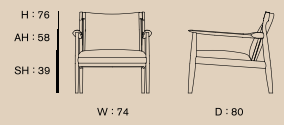

EASY CHAIR

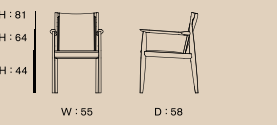

ARMCHAIR

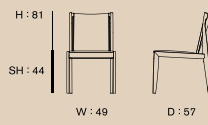

CHAIR

50 |

MARCEL

Design: SHINSAKU MIYAMOTO

Seat and back in fabric and leather
 Frame in walnut, oak

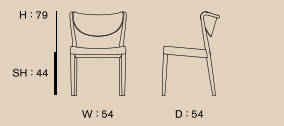

CHAIR

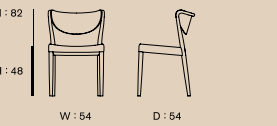

CHAIR

46 | 47 | 53

JK

Design: JUN KAMAHARA

Seat in fabric and leather for ARMCHAIR and thick leather for EASY CHAIR
 Back in thick leather
 black, taupe gray, ecru, amber, terracotta, burgundy, vintage brown and dark brown
 Frame in walnut, oak for ARMCHAIR and hairline stainless steel acrylic urethane coating with 6 colors for EASY CHAIR, classic rose, shiny brass, antique brass, shiny bronze, antique gray and shiny hairline



ARMCHAIR



EASY CHAIR

Hand stitch available for EASY CHAIR.

36 | 39 | 40 | 43

RIVAGE

Design: ATELIER D.Q.

Seat and back in fabric and leather
 Frame in walnut, oak for EASY CHAIR, ARMCHAIR, STOOL
 steel powder coating with black and hairline stainless steel acrylic urethane coating with 6 colors for LOUNGE CHAIR, classic rose, shiny brass, antique brass, shiny bronze, antique gray and shiny hairline
 Arm in walnut, oak for LOUNGE CHAIR



EASY CHAIR



ARMCHAIR



STOOL

Hand stitch available for back in leather except for STOOL



LOUNGE CHAIR

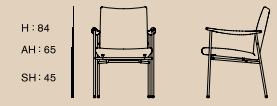

METAL ARMCHAIR

54 |

BLAVA

Design: ATELIER D.Q.

Seat and back in removable fabric and leather
 Belt in thick leather
 black, taupe gray, ecru, amber, terracotta, burgundy, vintage brown and dark brown
 Frame in walnut, oak

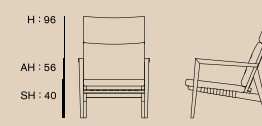

HIGH BACK EASY CHAIR

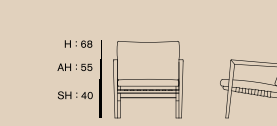

EASY CHAIR



OTTOMAN

52 |

LUPIN

Design: ATELIER D.Q.

Seat and back in fabric and leather
 Frame in walnut, oak
 Outside of seat and back in thick leather black, taupe gray, ecru, amber, terracotta, burgundy, vintage brown and dark brown

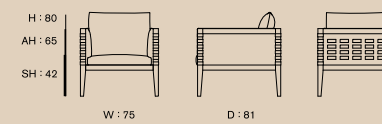

LOUNGE CHAIR

82 |
BEATRIX
 Design: SHINSAKU MIYAMOTO
 Seat and back in fabric and leather
 Frame in walnut, oak
 Shell in thick leather
 black, taupe gray, ecru, amber, terracotta, burgundy,
 vintage brown and dark brown

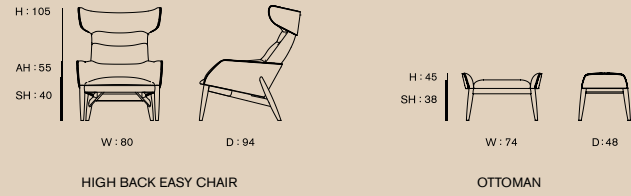

34 |
MT
 Design: SHINSAKU MIYAMOTO
 Seat in walnut, oak with thick leather webbing
 black, taupe gray, ecru, amber, terracotta, burgundy,
 vintage brown and dark brown
 Frame in steel powder coating with black
 and hairline stainless steel acrylic urethane coating
 with 6 colors, classic rose, shiny brass, antique brass,
 shiny bronze, antique gray and shiny hairline

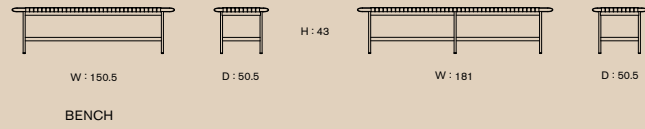

56 |
VINCENT
 Design: RITZWELL
 Seat with thick leather webbing
 black, taupe gray, ecru, amber, terracotta, burgundy,
 vintage brown and dark brown
 Frame in walnut, oak



30 | 31 | 32 | 33
MO BRIDGE
 Design: SHINSAKU MIYAMOTO
 Seat in walnut, oak with thick leather webbing
 black, taupe gray, ecru, amber, terracotta, burgundy,
 vintage brown and dark brown
 Frame in walnut, oak
 Top in walnut, oak upholstered in thick leather
 black, taupe gray, ecru, amber, terracotta, burgundy,
 vintage brown and dark brown

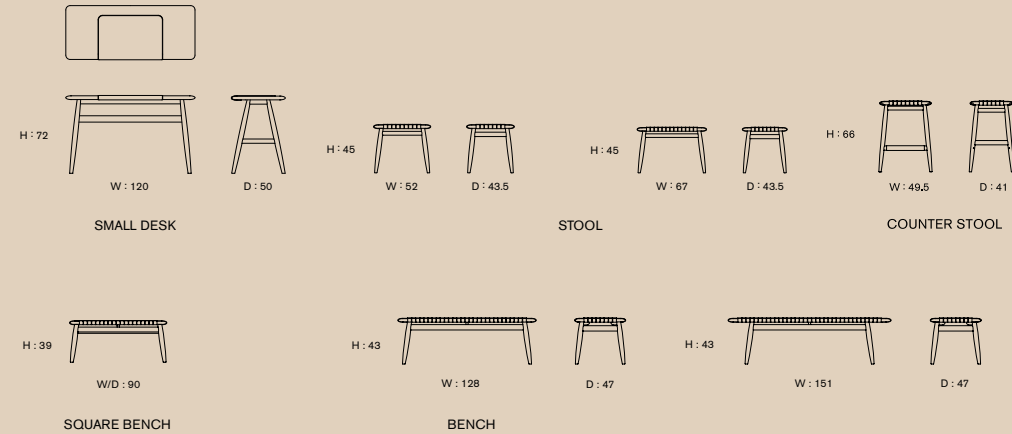

24 |
GQ TABLE
 Design: SHINSAKU MIYAMOTO
 Frame in thick leather black, taupe gray, ecru, amber,
 terracotta, burgundy, vintage brown and dark brown
 wrapped steel powder coating with black and hairline
 stainless steel acrylic urethane coating with 6 colors,
 classic rose, shiny brass, antique brass, shiny bronze,
 antique gray and shiny hairline
 Top in solid oak, walnut

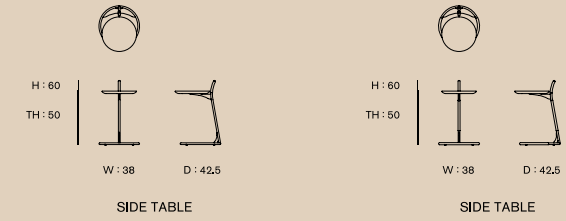

80 |
LEEWISE EXCLUSIVE
 Design: JUNICHIRO WATANABE & RITZWELL
 Top in oak
 Leg frame in white ash

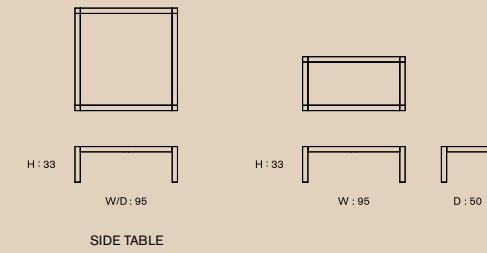

68 | 71
JK TABLE
 Design: JUN KAMAHARA
 Top in solid walnut
 Leg in steel powder coating with black and
 hairline stainless steel acrylic urethane coating
 with 6 colors, classic rose, shiny brass,
 antique brass, shiny bronze, antique gray
 and shiny hairline

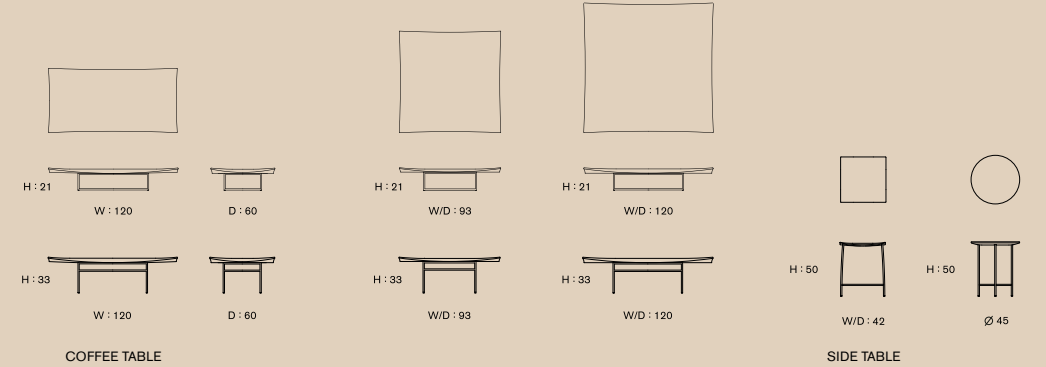

16 |
MT COFFEE TABLE
 Design: SHINSAKU MIYAMOTO
 Top in solid oak, walnut
 Frame in steel powder coating with black
 and hairline stainless steel acrylic urethane coating
 with 6 colors, classic rose, shiny brass, antique brass,
 shiny bronze, antique gray and shiny hairline

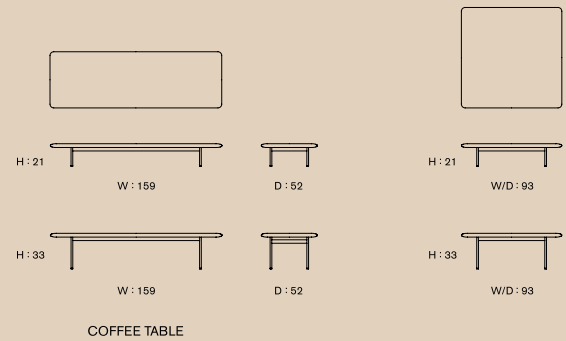

78 |

MT TABLE

Design: SHINSAKU MIYAMOTO

Top in solid oak, walnut

Frame in steel powder coating with black and hairline stainless steel acrylic urethane coating with 6 colors, classic rose, shiny brass, antique brass, shiny bronze, antique gray and shiny hairline

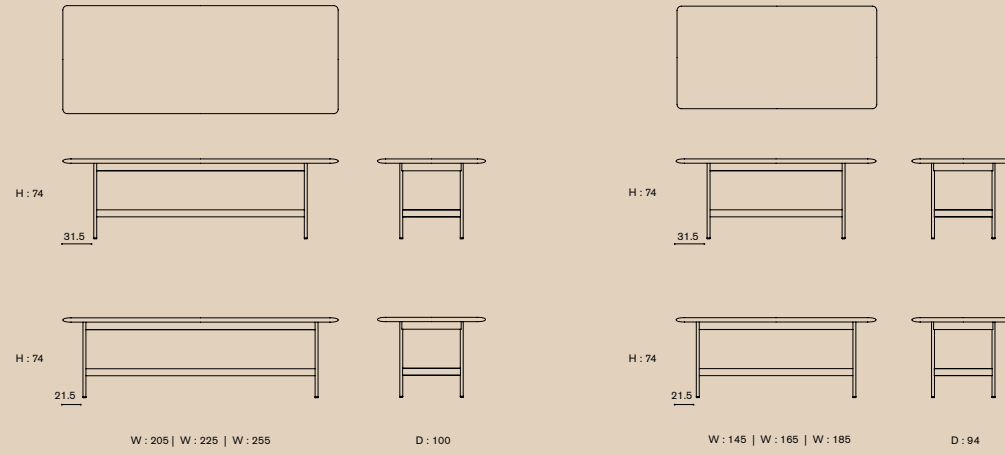

76 |

MCM TABLE

Design: SHINSAKU MIYAMOTO

Top and leg in solid walnut

Frame in steel powder coating with black

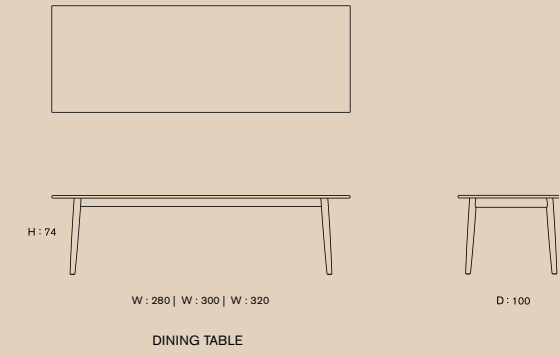

DINING TABLE

44 |

MTM TABLE

Design: RITZWELL

Top in solid oak, walnut

Frame in steel powder coating with black and hairline stainless steel acrylic urethane coating with 6 colors, classic rose, shiny brass, antique brass, shiny bronze, antique gray and shiny hairline

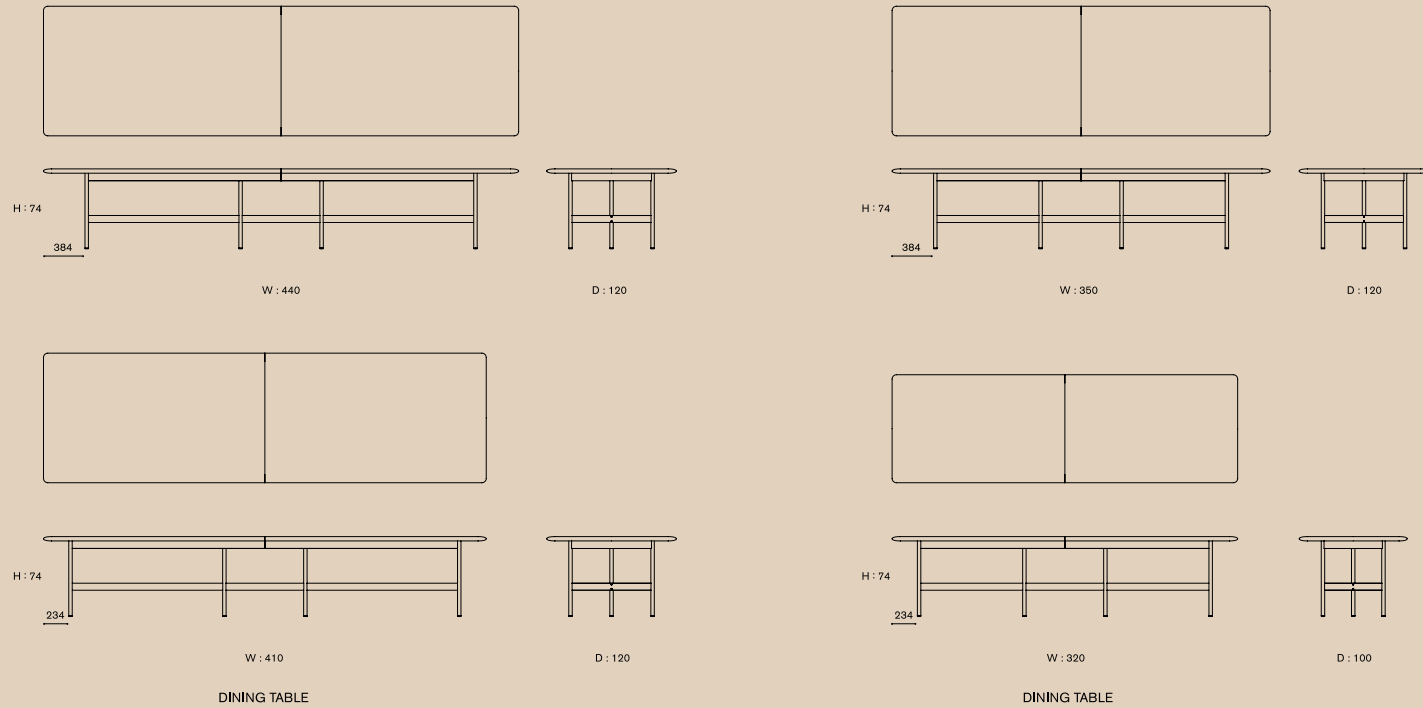

DINING TABLE

DINING TABLE

72 | 74

MO TABLE

Design: SHINSAKU MIYAMOTO

Top in solid oak, walnut

Leg in solid oak

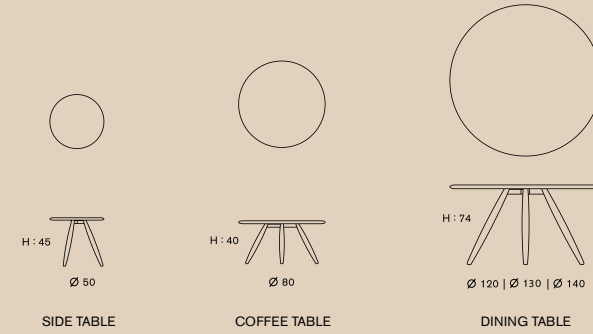

SIDE TABLE

COFFEE TABLE

DINING TABLE

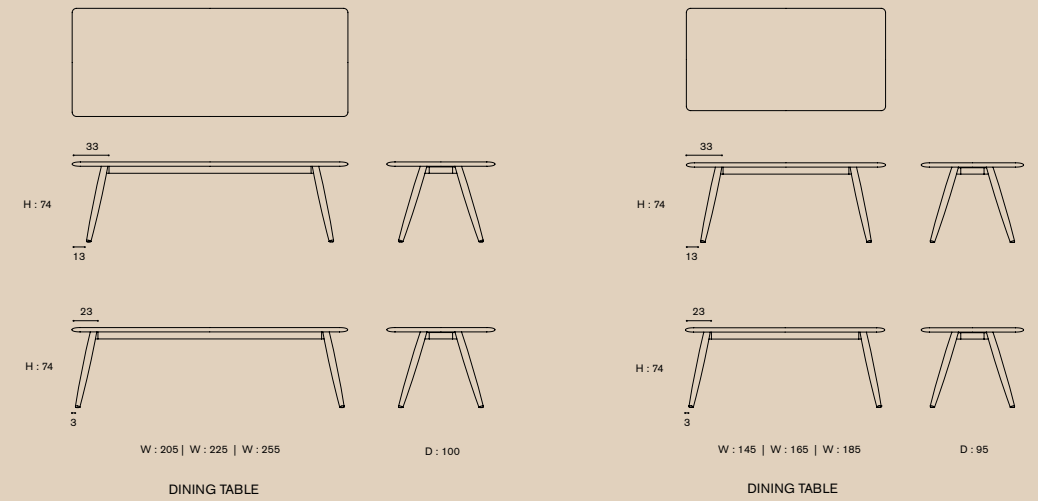

DINING TABLE

DINING TABLE

66 |

OS TABLE

Design: RITZWELL

Top in solid walnut, oak

Leg in steel powder coating with black and hairline stainless steel acrylic urethane coating with 6 colors, classic rose, shiny brass, antique brass, shiny bronze, antique gray and shiny hairline

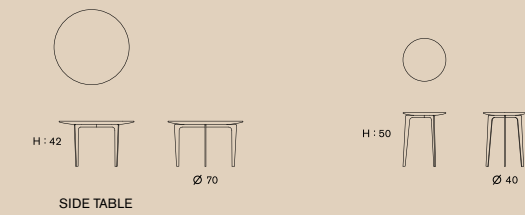

SIDE TABLE

04 |

VELAR

Design: SHINSAKU MIYAMOTO

Frame and cushion in removable fabric and upholstered fixed leather

Leg in steel powder coating with black and hairline stainless steel acrylic

urethane coating with 6 colors, classic rose, shiny brass, antique brass,

shiny bronze, antique gray and shiny hairline

Piping in artificial suede leather

- - - - Sewing scheme in leather



86 |

LIGHT FIELD

Design: SHINSAKU MIYAMOTO

Seat and back cushion in removable fabric and upholstered fixed leather

Outer panel in removable fabric, leather and upholstered fixed thick leather

Leg in steel powder coating with black and hairline stainless steel acrylic urethane coating with 6 colors, classic rose, shiny brass, antique brass, shiny bronze, antique gray and shiny hairline

Thick leather available in black, taupe gray, ecru, amber, terracotta, burgundy, vintage brown and dark brown

----- Sewing scheme in leather

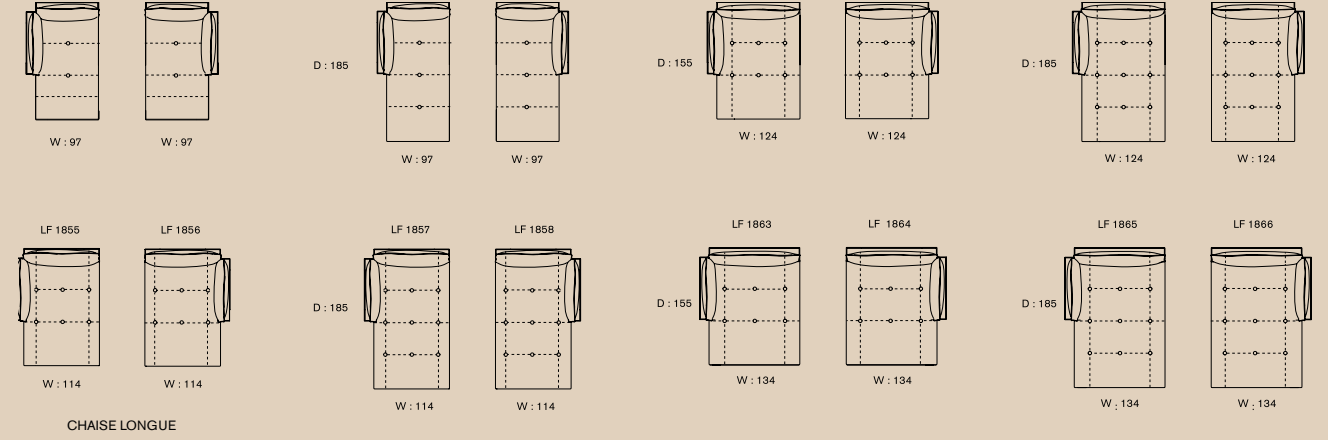
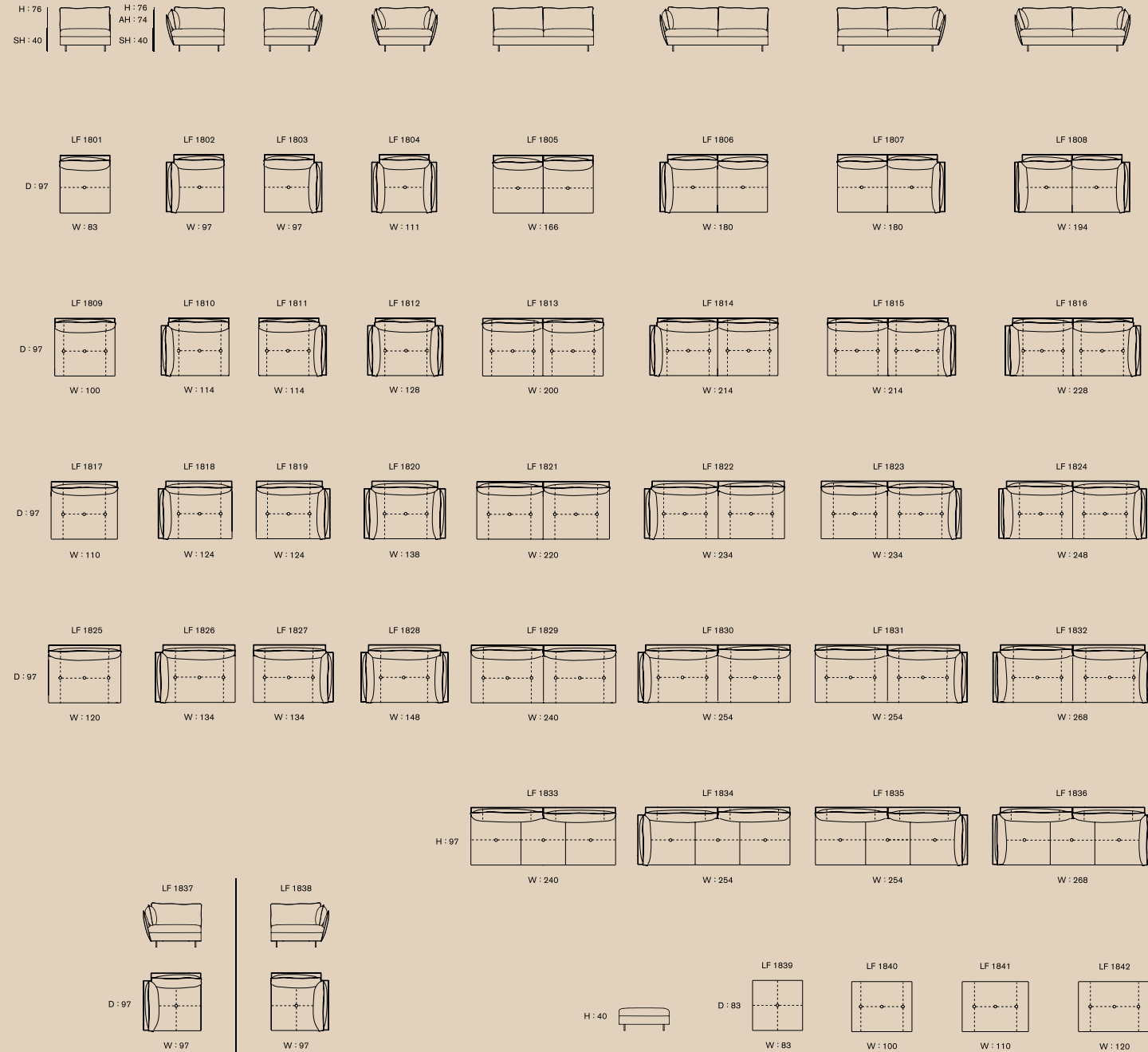

CHAISE LONGUE

92 |

DIANA

Design: SHINSAKU MIYAMOTO

Seat and back in removable fabric and leather

Frame cover in removable fabric and leather

Frame in walnut, oak

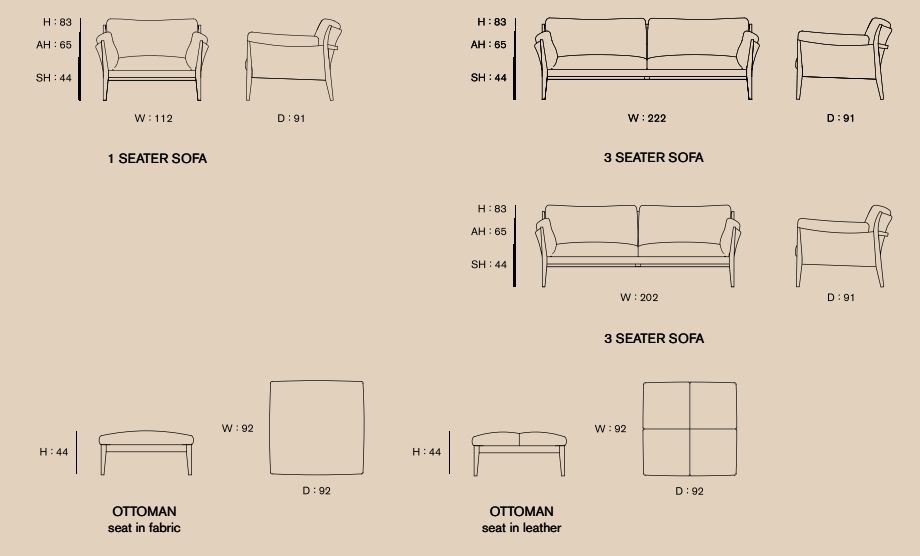

1 SEATER SOFA

3 SEATER SOFA

3 SEATER SOFA

OTTOMAN seat in fabric

OTTOMAN seat in leather

LEEWISE EXCLUSIVE

Design: JUNICHIRO WATANABE & RITZWELL

Seat and back cushion in removable fabric and leather

Wooden base frame structure in white ash

----- Sewing scheme in leather

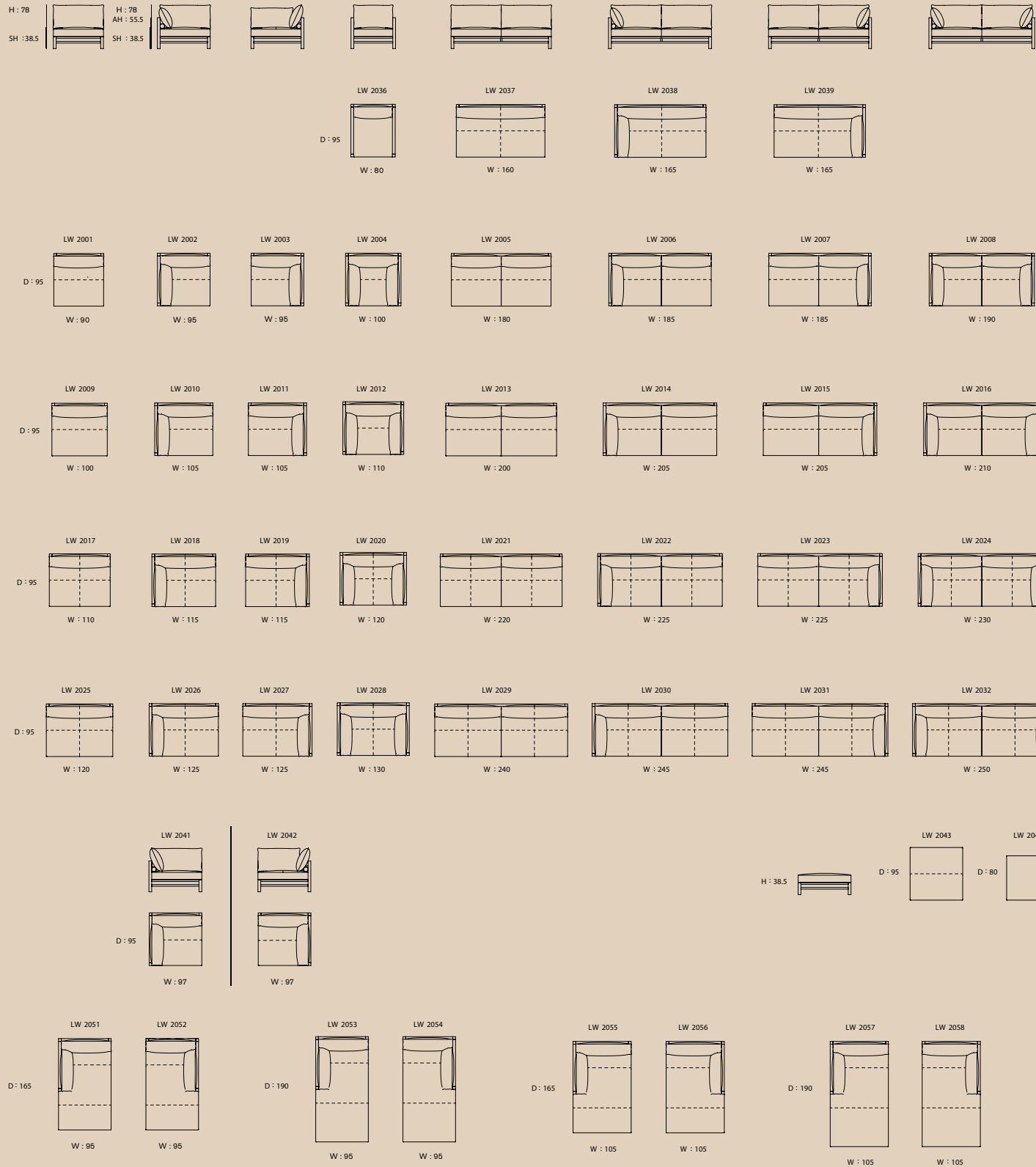

JABARA SIDEBOARD

Design: SHINSAKU MIYAMOTO

Body in walnut, oak

Base in steel powder coating with black and hairline stainless steel acrylic urethane coating with 6 colors, classic rose, shiny brass, antique brass, shiny bronze, antique gray and shiny hairline

Door in sliding tambour door

Front drawer in thick leather

black, taupe gray, ecru, amber, terracotta, burgundy, vintage brown and dark brown

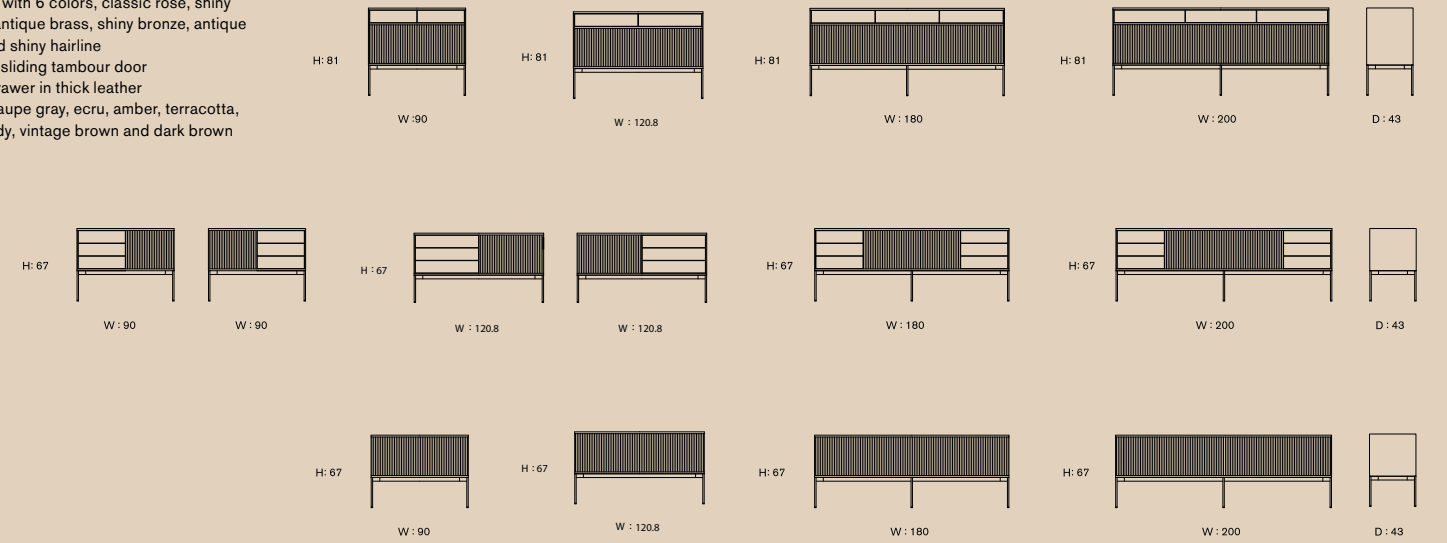

JABARA AV BOARD

Design: SHINSAKU MIYAMOTO

Body in walnut, oak

Base in steel powder coating with black and hairline stainless steel acrylic urethane coating with 6 colors, classic rose, shiny brass, antique brass, shiny bronze, antique gray and shiny hairline

Door in sliding tambour door and glass flap door

black, taupe gray, ecru, amber, terracotta, burgundy, vintage brown and dark brown

black, taupe gray, ecru, amber, terracotta, burgundy, vintage brown and dark brown

Door in sliding tambour door and glass flap door

black, taupe gray, ecru, amber, terracotta, burgundy, vintage brown and dark brown

black, taupe gray, ecru, amber, terracotta, burgundy, vintage brown and dark brown

black, taupe gray, ecru, amber, terracotta, burgundy, vintage brown and dark brown

black, taupe gray, ecru, amber, terracotta, burgundy, vintage brown and dark brown

black, taupe gray, ecru, amber, terracotta, burgundy, vintage brown and dark brown

black, taupe gray, ecru, amber, terracotta, burgundy, vintage brown and dark brown

black, taupe gray, ecru, amber, terracotta, burgundy, vintage brown and dark brown

black, taupe gray, ecru, amber, terracotta, burgundy, vintage brown and dark brown

black, taupe gray, ecru, amber, terracotta, burgundy, vintage brown and dark brown

black, taupe gray, ecru, amber, terracotta, burgundy, vintage brown and dark brown

black, taupe gray, ecru, amber, terracotta, burgundy, vintage brown and dark brown

black, taupe gray, ecru, amber, terracotta, burgundy, vintage brown and dark brown

black, taupe gray, ecru, amber, terracotta, burgundy, vintage brown and dark brown

black, taupe gray, ecru, amber, terracotta, burgundy, vintage brown and dark brown

black, taupe gray, ecru, amber, terracotta, burgundy, vintage brown and dark brown

black, taupe gray, ecru, amber, terracotta, burgundy, vintage brown and dark brown

black, taupe gray, ecru, amber, terracotta, burgundy, vintage brown and dark brown

black, taupe gray, ecru, amber, terracotta, burgundy, vintage brown and dark brown

black, taupe gray, ecru, amber, terracotta, burgundy, vintage brown and dark brown

black, taupe gray, ecru, amber, terracotta, burgundy, vintage brown and dark brown

black, taupe gray, ecru, amber, terracotta, burgundy, vintage brown and dark brown

black, taupe gray, ecru, amber, terracotta, burgundy, vintage brown and dark brown

black, taupe gray, ecru, amber, terracotta, burgundy, vintage brown and dark brown

black, taupe gray, ecru, amber, terracotta, burgundy, vintage brown and dark brown

black, taupe gray, ecru, amber, terracotta, burgundy, vintage brown and dark brown

black, taupe gray, ecru, amber, terracotta, burgundy, vintage brown and dark brown

black, taupe gray, ecru, amber, terracotta, burgundy, vintage brown and dark brown

black, taupe gray, ecru, amber, terracotta, burgundy, vintage brown and dark brown

black, taupe gray, ecru, amber, terracotta, burgundy, vintage brown and dark brown

black, taupe gray, ecru, amber, terracotta, burgundy, vintage brown and dark brown

black, taupe gray, ecru, amber, terracotta, burgundy, vintage brown and dark brown

black, taupe gray, ecru, amber, terracotta, burgundy, vintage brown and dark brown

black, taupe gray, ecru, amber, terracotta, burgundy, vintage brown and dark brown

black, taupe gray, ecru, amber, terracotta, burgundy, vintage brown and dark brown

black, taupe gray, ecru, amber, terracotta, burgundy, vintage brown and dark brown

black, taupe gray, ecru, amber, terracotta, burgundy, vintage brown and dark brown

black, taupe gray, ecru, amber, terracotta, burgundy, vintage brown and dark brown

black, taupe gray, ecru, amber, terracotta, burgundy, vintage brown and dark brown



reddot design award
winner 2018



reddot design award
winner 2019



reddot design award
best of the best 2019



reddot winner 2024

AS AWARDED BY THE DESIGN ZENTRUM NORDRHEIN WESTFALEN E.V.



DESIGN
AWARD
2017



DESIGN
AWARD
2022

AS AWARDED BY IF INTERNATIONAL FORUM DESIGN GMBH



GERMAN
DESIGN
AWARD
WINNER
2019



GERMAN
DESIGN
AWARD
SPECIAL
2019

AS AWARDED BY THE GERMAN DESIGN COUNCIL, THE AUTHORITATIVE GERMAN



archiproducts
DESIGN AWARDS
WINNER 2018



archiproducts
DESIGN AWARDS
WINNER 2019



archiproducts
DESIGN AWARDS
WINNER 2020



archiproducts
DESIGN AWARDS
WINNER 2021



archiproducts
DESIGN AWARDS
WINNER 2022

archiproducts
AWARDS
2023 WINNER

archiproducts
AWARDS
2024 WINNER

AS AWARDED BY ARCHIPRODUCTS



THANKS FOR THE LIGHTING:

Tooy, suspension light Lilly | 75

Roll & Hill, suspension light Modo Chandelier | 77

Roll & Hill, suspension light Agnes Chandelier | 79

Paolo Castelli S.p.A., floor light For Hall Lamp | 91

Photo credits: Alberto Strada | 72

GRAPHIC DESIGN

UNTITLED-AGENCY Milano

PRINTED IN ITALY

ARTI GRAFICHE MERONI

Ritzwell

RITZWELL & CO. | TOKYO | OSAKA | FUKUOKA

RITZWELL ITALIA S.R.L. | MILANO

info@ritzwell.com | www.ritzwell.com

follow us @ritzwell_official